

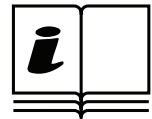

User's Manual & Operating Instructions

Model Numbers
FF 45 / FF 70 / FF 125 /
FF 175 / FF 215

FACTORY ID: 001



CONSUMER: READ AND SAVE THESE INSTRUCTIONS

▲ DANGER **GENERAL HAZARD WARNING:**
READ AND UNDERSTAND ALL OF THE INSTRUCTIONS IN THIS MANUAL BEFORE ASSEMBLING, STARTING, OR SERVICING THE HEATER. Be sure to comply with the instructions and warnings provided with this heater. Failure to comply can result in fire or explosion that can cause property loss, bodily injury, or loss of life. Only persons who can follow and understand these instructions should operate or service this heater.

▲ DANGER **NOT FOR USE IN RESIDENTIAL LIVING AREAS OR IN ENCLOSED SPACES WITHOUT ADEQUATE VENTILATION. INDOOR USE PERMITTED ONLY FOR THE TEMPORARY HEATING OF BUILDINGS OR STRUCTURES UNDER CONSTRUCTION, ALTERATION OR REPAIR.** This is an unvented portable heater that uses air (Oxygen) from within the area in which it is used. Failure to provide adequate combustion and ventilation air will result in asphyxiation, carbon monoxide poisoning, bodily injury or death. Refer to "Ventilation" on Page 7.

▲ WARNING This appliance shall be installed in accordance with the rules in force, and used only in sufficiently ventilated space. Consult instructions before installation and use of this appliance.

Table Of Contents

Safety Information.....	1-2	Maintenance.....	9-11
Features and Specifications.....	3	Wiring Diagram.....	11
FF 45 and FF 70 Assembly.....	4	Troubleshooting Guide.....	12
125/ 175 / FF 215 Assembly.....	5-6	Exploded View.....	13
Operation.....	7-6	Parts List.....	14
Ventilation.....	7		

Safety Information

▲WARNING **FIRE, BURN, INHALATION AND EXPLOSION HAZARD.** Keep combustibles such as; building materials, paper or cardboard a safe distance away from the heater as recommended by these instructions. Never use the heater in spaces which contain products such as gasoline, solvents, paint thinners, dust particles, volatile or airborne combustibles or any unknown chemicals. This is an unvented portable heater. It uses air (Oxygen) from the area in which it is used. Adequate combustion and ventilation air must be provided. Refer to "Ventilation" on page 7. Bulk fuel storage should be a minimum of 25 feet from heater.

▲WARNING **DO NOT OPERATE THIS HEATER UNTIL YOU HAVE READ AND THOROUGHLY UNDERSTAND THESE SAFETY AND OPERATING INSTRUCTIONS.**

Failure to comply with the precautions and instructions provided with this heater can result in death, serious bodily injury, property loss or damage from the hazards of fire, soot production, explosions, burns, asphyxiation or carbon monoxide poisoning. Only persons who can read and understand these instructions should use or service this heater.

▲WARNING **DO NOT START THE HEATER WHEN EXCESS OIL HAS ACCUMULATED.**

▲WARNING **DO NOT START THE HEATER WHEN THE CHAMBER IS HOT.**

THE INSTALLATION OF THIS HEATER SHALL COMPLY WITH THE REGULATIONS OF THE AUTHORITIES HAVING JURISDICTION.

This appliance can be used by children aged from 8 years and above and persons with reduced physical, sensory or mental capabilities or lack of experience or and knowledge if they have been given supervision or instruction concerning use of the appliance in a safe way and understand the hazards involved. Children shall not play with the appliance. Cleaning and user maintenance shall not be made by children without supervision.

i **Look for this icon throughout the manual for helpful tips on how to assemble, use and clean your KFA Heater.**

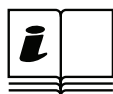

Read The Instruction manual: When this symbol is marked on a product, it means that the instruction manual must be read.



WARNING! Never touch heater until heater has cooled off.

Safety Information

▲ WARNING RISK OF INDOOR AIR POLLUTION!

The products described in this manual are paraffin direct-fired, forced air heaters. Paraffin forced air heaters are primarily intended for use for temporary heating of buildings under construction, alteration or repair. Direct-fired means that all of the combustion products of the heater enter the heated space. This appliance is rated at 98% combustion efficiency, but does produce small amounts of carbon monoxide. Carbon monoxide is toxic. Humans can tolerate

▲ WARNING CARBON MONOXIDE POISONING MAY LEAD TO DEATH!

only small amounts of carbon monoxide and so precautions should be taken to provide proper ventilation. Failure to provide proper ventilation in accordance with the instructions in this manual can result in death.

People with breathing problems should consult a physician before using this heater.

Early signs of carbon monoxide poisoning resemble the flu. Symptoms of improper ventilation / carbon monoxide poisoning are:

**Headache • Dizziness • Nausea • Dry Mouth
Sore Throat • Burning of Nose and Eyes**

If you experience any of these symptoms: **GET FRESH AIR AT ONCE!** Have your heater serviced and check for proper ventilation. Some people are more affected by carbon monoxide than others. These include: pregnant women, those with heart or lung problems, anemia or those under the influence of alcohol or at high altitudes.

Not For Indoor Use. Indoor use permitted only for the temporary heating of buildings under construction, alteration or repair! Provide at least a three square foot (2,800 sq cm) opening of outside air for every 100,000 Btu / Hr heater rating. Refer to “Ventilation” on page 7 for further instructions.

▲ WARNING RISK OF ELECTRIC SHOCK!

ALWAYS use only the electrical power (voltage and frequency) specified on the model plate of the heater. ALWAYS use only approved, grounded socket and properly rated extension cables. ALWAYS unplug the heater when not in use. ALWAYS install the heater so that it is not directly exposed to water spray, rain, dripping water, or wind. If the supply cord is damaged, it must be replaced by a special cord or assemble available from the manufacturer, its service agent or similarly qualified persons in order to avoid a hazard

▲ WARNING RISK OF BURNS, FIRE AND EXPLOSION!

NEVER use fuels such as gasoline, benzene, paint thinners or other oil compounds in this heater. NEVER refill the heater’s fuel tank while the heater is operating or still hot. This heater is **EXTREMELY HOT** while in operation. NEVER block air inlet (rear) or air outlet (front). NEVER use duct work in front or rear of heater. NEVER move or handle heater while still hot. NEVER transport heater with fuel in tank. NEVER use with an external fuel tank. Keep all combustible materials away from this heater.

▲ WARNING CAUTION! HOT WHILE IN OPERATION. DO NOT TOUCH. KEEP CHILDREN, ANIMALS, CLOTHING AND COMBUSTIBLES AWAY FROM HEATER.

Minimum Clearance From Combustibles

	FF 45	FF 70	FF 125	FF 175	FF 215
Top	1.2 m	1.2 m	1.2 m	1.2 m	1.2 m
Sides	1.2 m	1.2 m	1.2 m	1.2 m	1.2 m
Front	2.4 m	2.4 m	2.4 m	2.4 m	3.1 m

ALWAYS locate heater on a stable and level surface.

If your heater is equipped with a thermostat, once it is plugged in, it can start at anytime in accordance with the thermostat setting.

Specifications

Model #	FF 45	FF 70	FF 125	FF 175	FF 215
Rating: kW	13.0	20.5	36.6	51.2	63.0
Fuel Consumption: L/Hr	1.32	2.00	3.60	5.07	6.17
Fuel Tank Capacity: Liters	19	19	38	49	49
Pump Pressure: PSI /BAR	3.0 / 0.21	3.7 / 0.26	4.5 / 0.31	6.5 / 0.45	8.0 / 0.55
Volts: AC/Hz	230VAC / 50Hz	230VAC / 50Hz	230VAC / 50Hz	230VAC / 50Hz	230VAC / 50Hz
Phase	Single	Single	Single	Single	Single

Specifications subject to change without notice.

Features

Models: FF 45 / FF 70

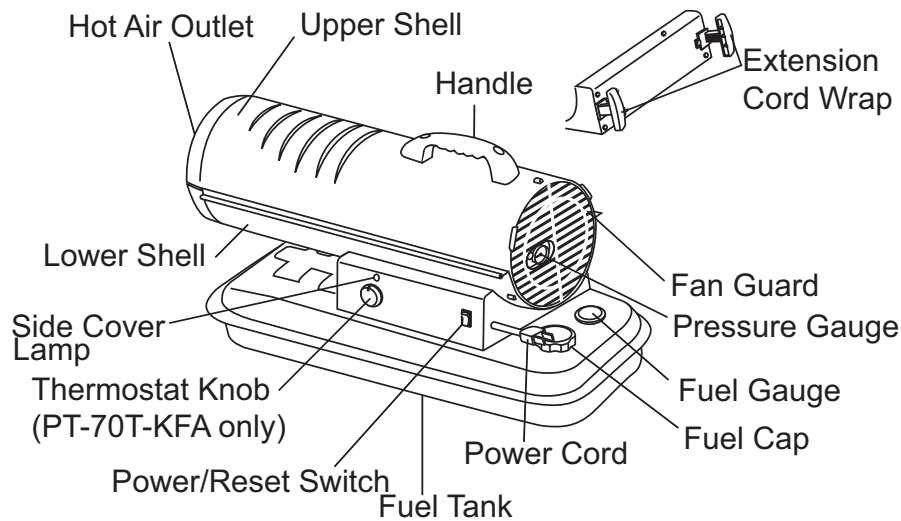

Figure 1

Models: FF 125 / FF 175 / FF 215

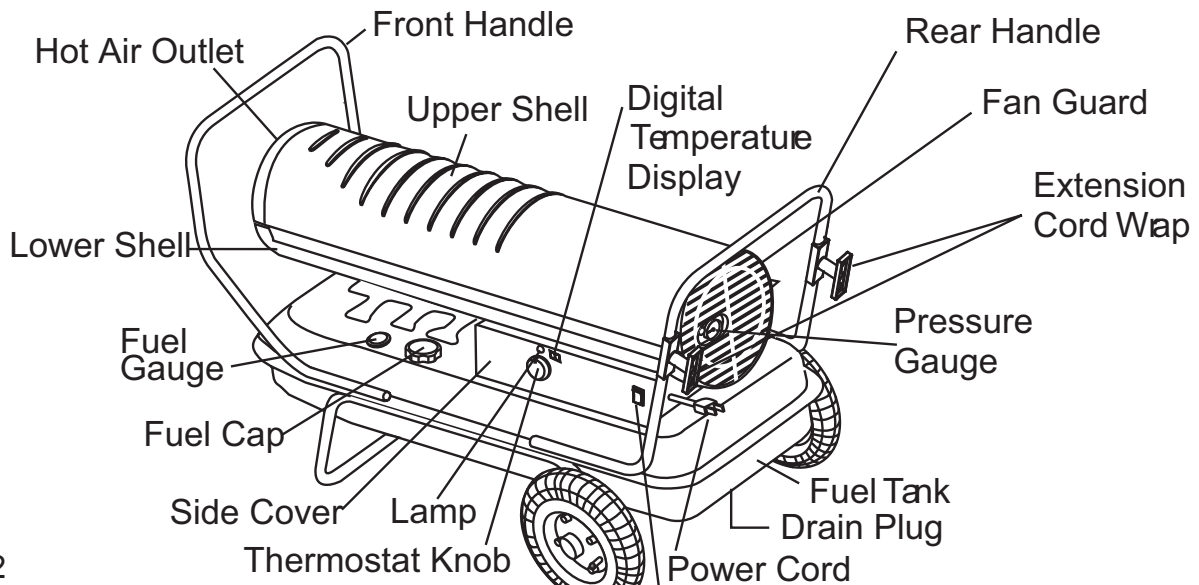

Figure 2

Assembly Instructions

Models: FF 45 / FF 70

- Remove the heater and all packaging materials from the shipping carton

Note: Save the box and packaging materials for future storage.

What's In The Box

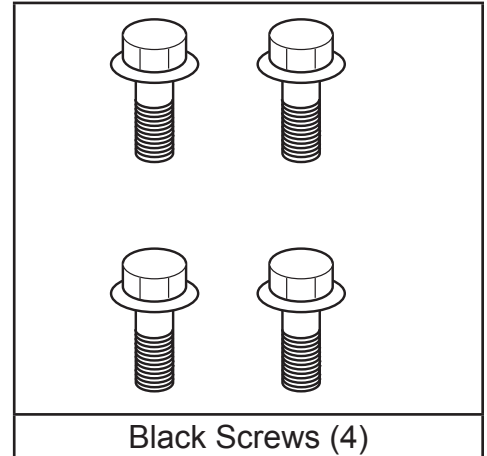
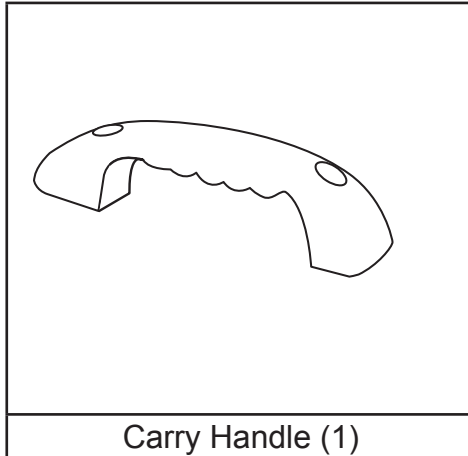
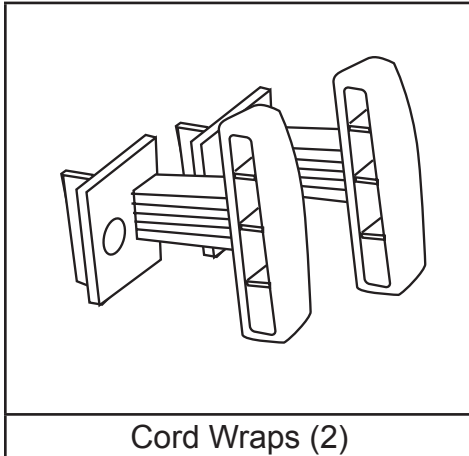

Carry Handle Assembly

1. Align holes in the upper housing with the 2 holes in the handle as shown in Figure 3.
2. Insert screws and tighten firmly.

Cord Wrap Assembly

1. Insert tabs into square slots in shell support and line up screw holes as shown in Figure 4.
2. Insert screws and tighten firmly.

Tools Needed:

- Phillips Head Screw Driver

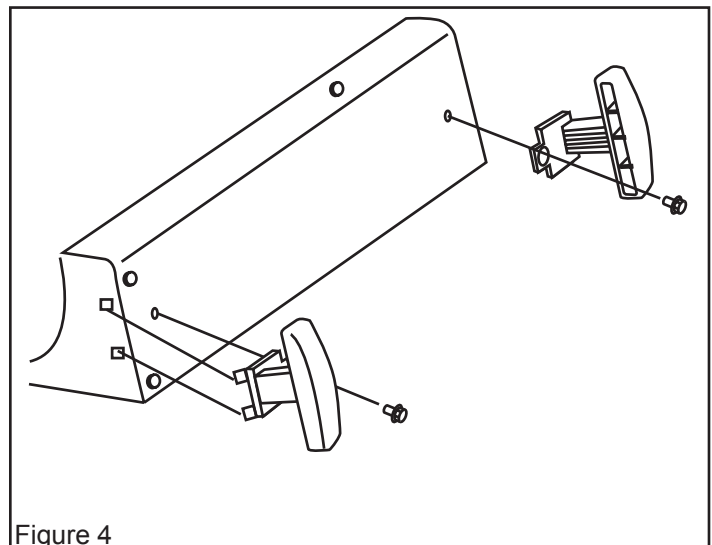
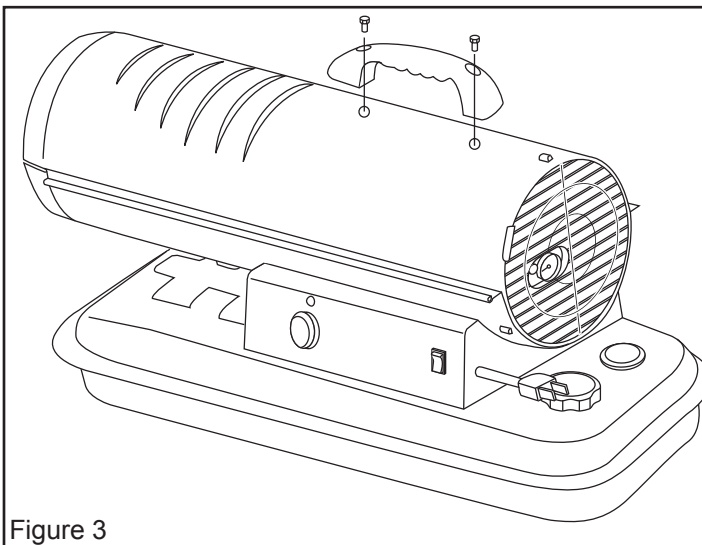

Assembly Instructions

Models: FF 125 / FF 175 / FF 215

- Remove the heater and all packaging materials from the shipping carton.

i *Tip: Be sure to remove the axle from the side of the Styrofoam packaging.*

Tools Needed:

- Phillips Head Screw Driver
- 8 mm open end wrench
- 19 mm open end wrench

i *Tip: Use a power screwdriver and locking wrench for easier assembly.*

What's In The Box

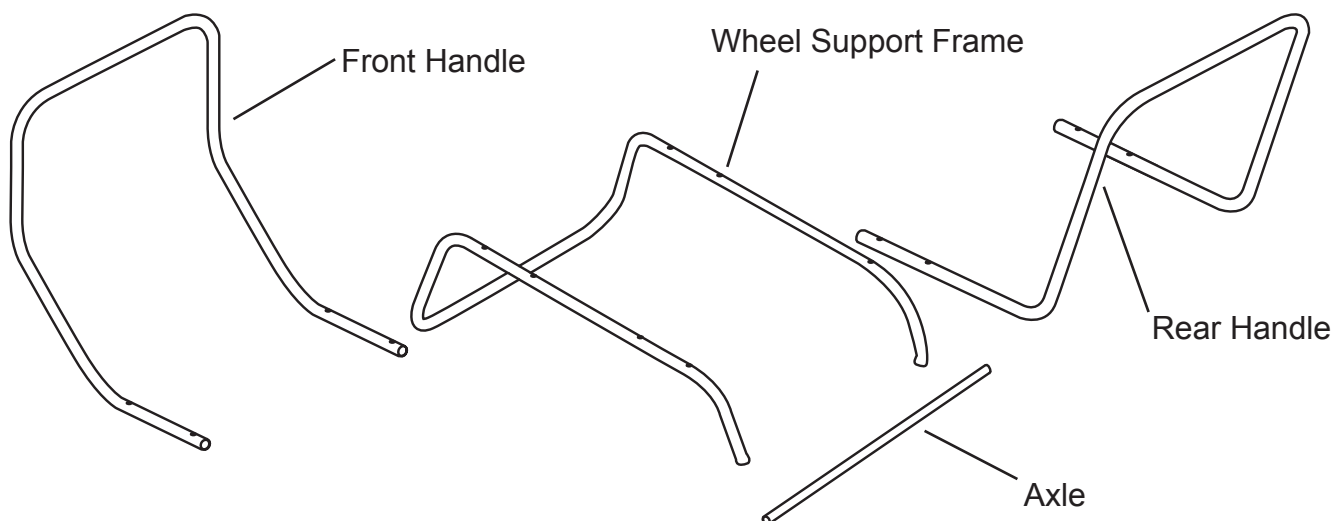
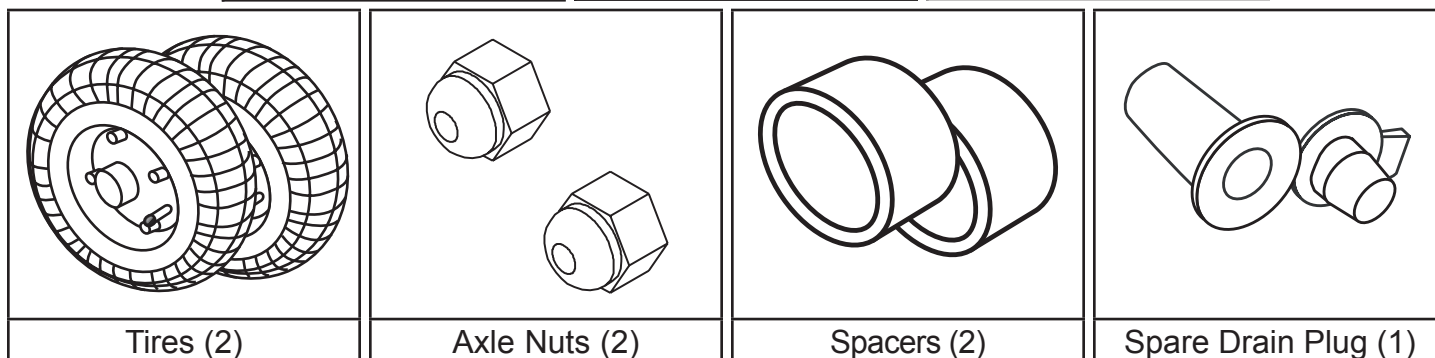
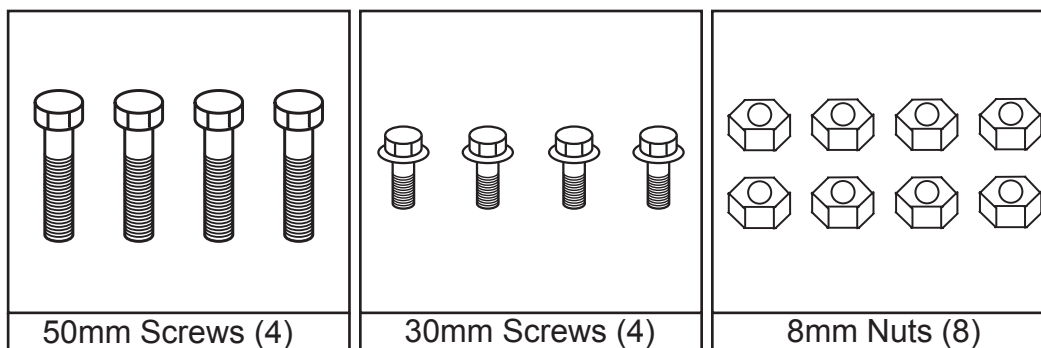

Assembly Instructions

Models: FF 125 / FF 175 / FF 215

1. Insert axle through holes in wheel support.
2. Slide washer, then spacer onto axle.
3. Slide wheel onto axle and hold in place with the axle nuts. (See Figure 5).

10. Secure the rear handle with (2) short screws (30 mm) and (2) nuts and tighten firmly
11. Replace wheels with the valve facing out and tighten with the wheel nuts.
12. Tilt heater back down onto wheels and check all screws and nuts to make sure they are secure.

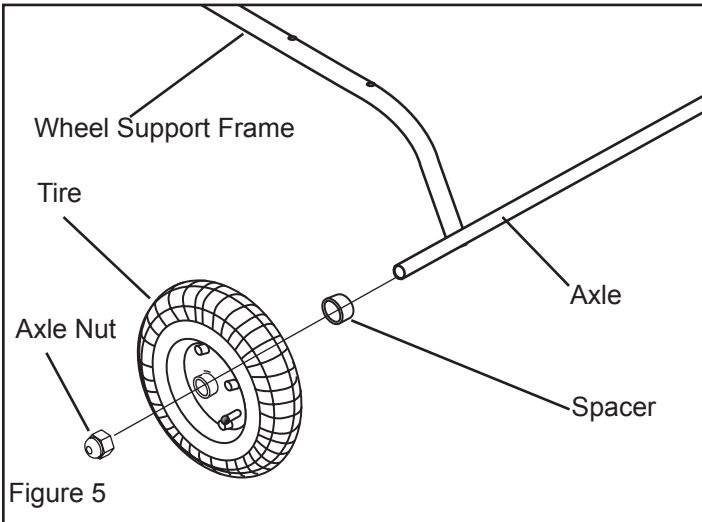

i Tip: Do not tighten the nuts fully. You will need to remove the wheels in a later step.

4. Place heater on wheel support and line up holes on the fuel tank lip.
5. Attach front handle with (2) long screws (50 mm) and (2) nuts through the second hole from the front on both sides of the tank lip and wheel support frame and tighten firmly.
6. Insert (2) short screws (30 mm) through the first hole from the front in the tank lip and tighten firmly. Make certain all (4) screws are secure.
7. Attach rear handle with (2) long screws (50 mm) and (2) nuts through the third hole from the rear of the heater on either side. (See Figure 6)
8. Tilt the heater up gently so it is resting on the front handle.

i Tip: You will secure the back of the rear handle in a later step by tilting the heater up the front handle as shown in figure 7

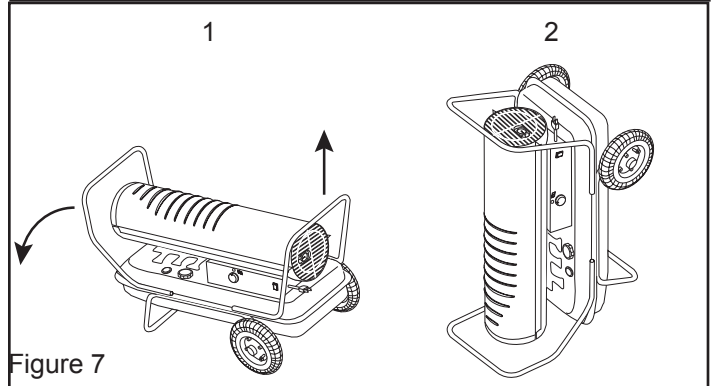
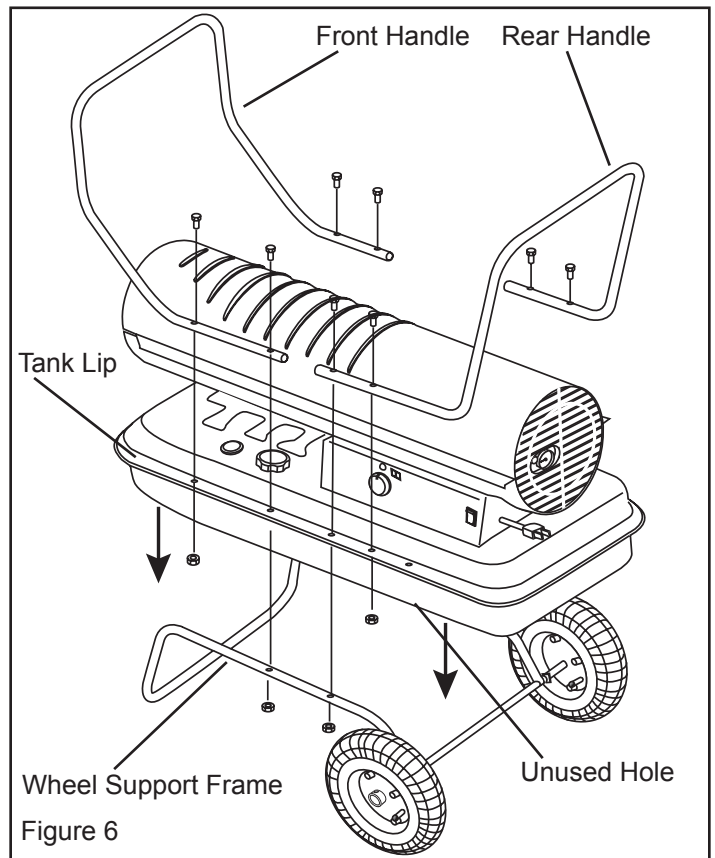

NOTE: DO NOT do this if there is fuel in the tank.

9. Remove the wheels to secure the second set of screws through the rear handle.

Operation

Fueling The Heater:

Paraffin

For optimal performance of this heater, it is strongly suggested that paraffin be used. Paraffin has been refined to virtually eliminate contaminants, such as sulfur, which can cause a rotten egg odor during the operation of the heater. Using diesel fuel can cause excess soot production. Do not use Bio-Diesel as this fuel will damage your heater's seals and filter.

▲ DANGER NEVER REFUEL THIS HEATER WHILE IT IS HOT OR OPERATING. FIRE OR EXPLOSION COULD RESULT.

▲ CAUTION NEVER FILL THE FUEL TANK INDOORS. ALWAYS FILL THE TANK OUTDOORS. BE SURE THAT THE HEATER IS ON LEVEL GROUND WHEN FUELING, AND NEVER OVERFILL THE TANK.

▲ WARNING DO NOT USE GASOLINE OR CRANKCASE DRAININGS.

- NEVER use fuel such as benzene, alcohol, white glass, camp stove fuel, paint thinners, or other oil compounds in this heater. THESE ARE VOLATILE FUELS THAT CAN CAUSE A FIRE OR EXPLOSION.
- NEVER store paraffin in the living space. Paraffin should be stored in a well ventilated area outside the living area.
- NEVER store paraffin in direct sunlight or near a source of heat.
- NEVER use paraffin that has been stored from one season to the next. Paraffin deteriorates over time. OLD Paraffin WILL NOT BURN PROPERLY IN THIS HEATER.

NOTE: Paraffin should only be stored in a blue container that is clearly marked "Paraffin." Never store paraffin in a red container. Red is associated with gasoline.

Ventilation:

- Risk of indoor air pollution and Carbon Monoxide Poisoning. Use heater only in well ventilated areas.
- Refer to Safety Information on pages 1-2 for information about Carbon Monoxide Poisoning.
- **ALWAYS** provide a fresh air opening in the heated space of at least 2,800 cm² for each 29 kW of heater output. Provide a larger opening if more heaters are being used.

▲ DANGER CARBON MONOXIDE POISONING MAY LEAD TO DEATH!

Minimum Ventilation Opening Needed				
FF 45	FF 70	FF 125	FF 175	FF 215
1.4 ft. ²	2.1 ft. ²	3.8 ft. ²	5.3 ft. ²	6.5 ft. ²
43 cm ²	64 cm ²	116 cm ²	162 cm ²	199 cm ²

▲ WARNING This appliance is designed to operate safely at a minimum ambient temperature of -20° C.

▲ WARNING Use caution when servicing in wet areas. Disconnect power from the power mains and keep all electrical components from becoming wet. Only a qualified technician should service the heater

▲ WARNING A qualified technician is required to install, adjust and, where necessary, convert this heater for use with other fuel types.

Operation

Starting the Heater: (Ignition)

1. Fill the tank with paraffin or other approved fuel until needle on fuel gauge points to "F".
2. Replace fuel cap and tighten firmly.
3. Connect the heater to a three prong (grounded) power source. You must use a three prong (grounded) extension cord that is at least 1.8 meters long and is properly rated for this service.

Model FF 45:

1. Complete steps 1-3 above.
2. Move power switch to "On" position. The power indicator light will illuminate and the heater will ignite. (See Figure 9)

NOTE: If if the heater still does not ignite, refer to "Troubleshooting Guide" on page 12.

***i* TIP:** *If the heater does not ignite; move switch to "Off" position, check steps 1-3 above and then move switch to "On" position.*

Stopping / Restarting Heater:

- To stop the heater, move the power switch to the "Off" position and unplug the power cord.
- To restart the heater; wait 10 seconds and follow ignition steps.

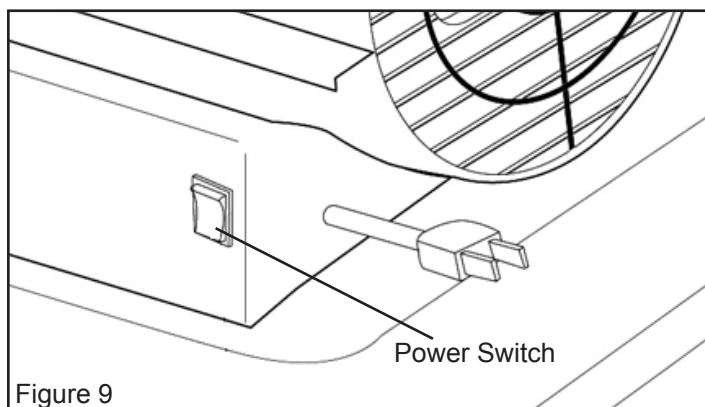

Figure 9

Models FF 70 / FF 125 /

FF 175 / FF 215:

1. Complete "starting heater ignition" steps 1-3 above.
2. Turn thermostat control knob to desired temperature setting. The thermostat set range is from 4.5 °C to 43.4 °C.
3. Move power switch to "On" position. The power indicator light and room temperature display will illuminate and heater will ignite. (See Figure 10)

***i* TIP:** *If the heater does not ignite, the thermostat may be set too low. Turn the control knob to a higher setting until the heater ignites. If the heater does not ignite; move switch to "Off" position, check steps 1-3 above and then move switch to "On" position.*

NOTE: If if the heater still does not ignite, refer to "Troubleshooting Guide" on page 12.

NOTE: The FF 45 and FF 70 do not have a room temperature display feature.

The room temperature display will indicate the following:

- When the temperature is less than -17.8 °C the display says "LO".
- When the temperature is more that 37.3 °C the display says "HI".
- Between -17.8 °C and 37.3 °C the display shows actual temperature.

Stopping / Restarting Heater:

- To stop the heater, move the power switch to the "Off" position and unplug the power cord.
- To restart the heater; wait 10 seconds and follow ignition steps.

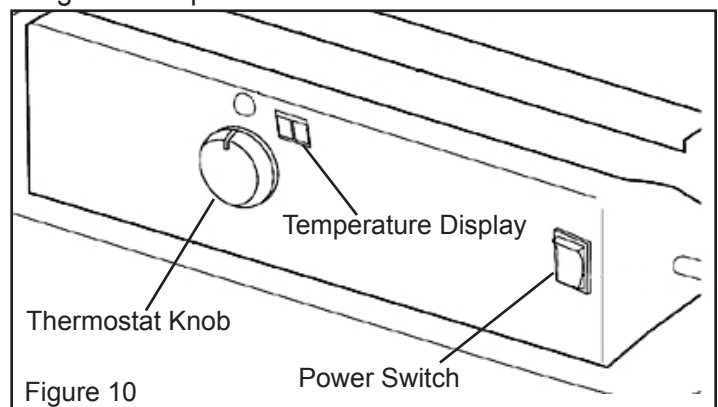

Figure 10

Maintenance

Long Term Storage:

Models FF 45 / FF 70:

1. Use an approved siphon to drain fuel through the fuel cap opening.

Models FF 125 / FF 175 / FF 215:

1. Drain fuel through the drain plug in the bottom of the fuel tank.
2. To remove the drain plug, pull the plug grip downward and remove the seal head from the drain hole in the tank. (See Figure 11)

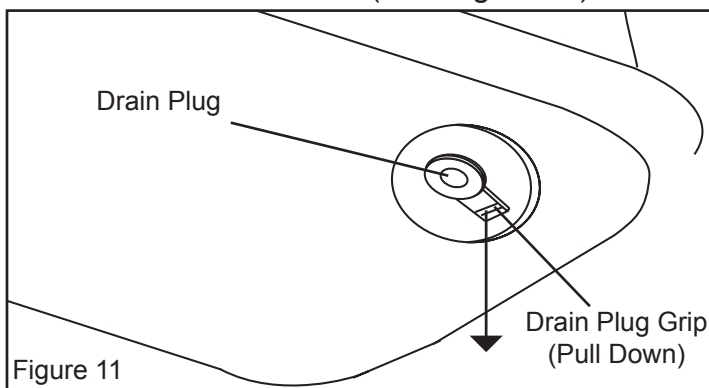

3. Using a small amount of paraffin, rinse and swirl the paraffin inside of the fuel tank, empty the tank fully.
4. To replace the drain plug; push the drain head fully into the drain hole and secure by pushing the seal cap fully into the head hole. (See Figure 12)

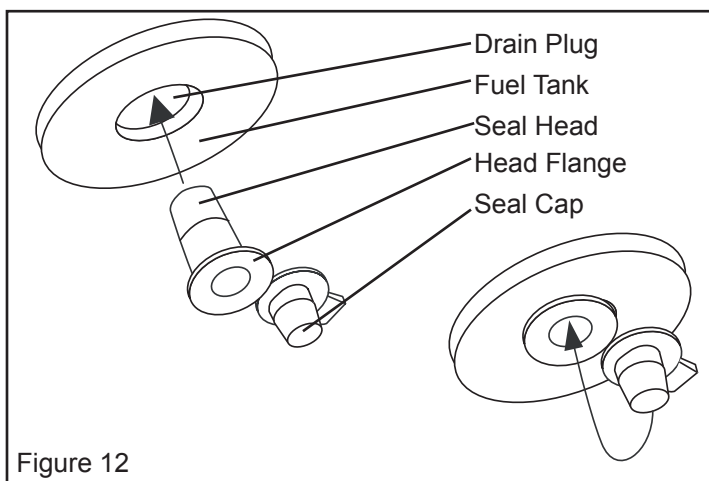

IMPORTANT: Never store leftover paraffin between seasons, using old fuel can damage heater.

Service:

▲ WARNING Never service heater while it is plugged in or hot!

DO NOT TAMPER WITH THE UNIT. HAVE A COMPETENT SERVICEMAN MAKE ANY NECESSARY ADJUSTMENT OR REPAIRS.

Use only original equipment parts. The use of alternate or third party components can cause unsafe operating conditions.

We suggest following a maintenance schedule as follows:

FUEL / FUEL TANK:

Flush tank every 200 hours of operation or as needed.

i TIP: Follow the long term storage instructions to flush the tank.

DO NOT flush with water, use fresh paraffin only.

AIR FILTERS:

The air intake filter should be replaced or washed with soap and water and dried thoroughly every 500 hours of operation or less depending on conditions.

The output and lint filters should be replaced every 500 hours of operation or less depending on conditions.

NOTE: Use of diesel fuel may require additional maintenance

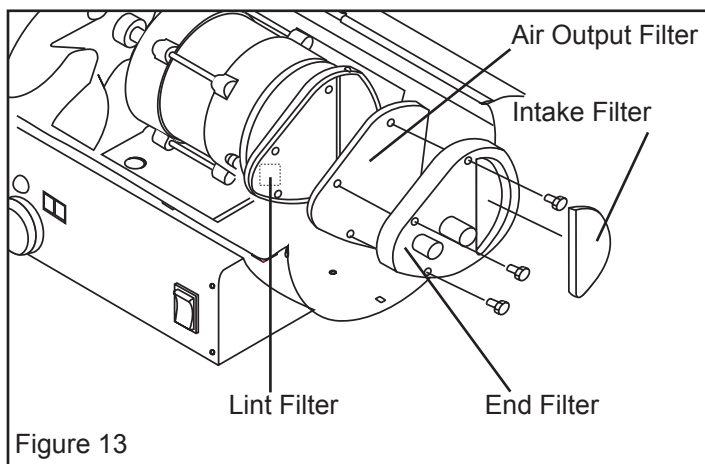

Maintenance

Service (Continued):

FAN BLADES:

Blades should be cleaned at least once per heating season, depending on conditions. Remove all accumulated dust and dirt with a damp cloth, taking care not to bend any of the fan blades. Be sure the blades are dry before re-starting the heater. For fan assembly removal see Figure 14.

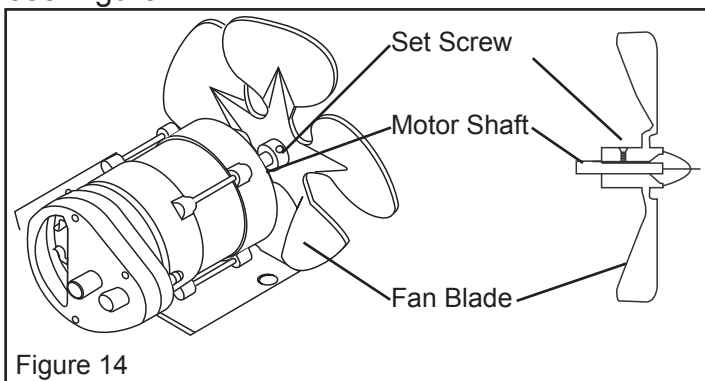

Figure 14

FUEL FILTER:

The fuel filter should be cleaned at least twice per heating season. Clean the filter by rinsing it in clean Paraffin. Contaminated fuel could make cleaning the fuel filter necessary immediately.

NOTE: To remove the filter from models FF 45 / FF 70 turn filter 90° clockwise. To remove the filter from models 125 / 175 / FF 215 turn filter 90° counter-clockwise. See Figure 15.

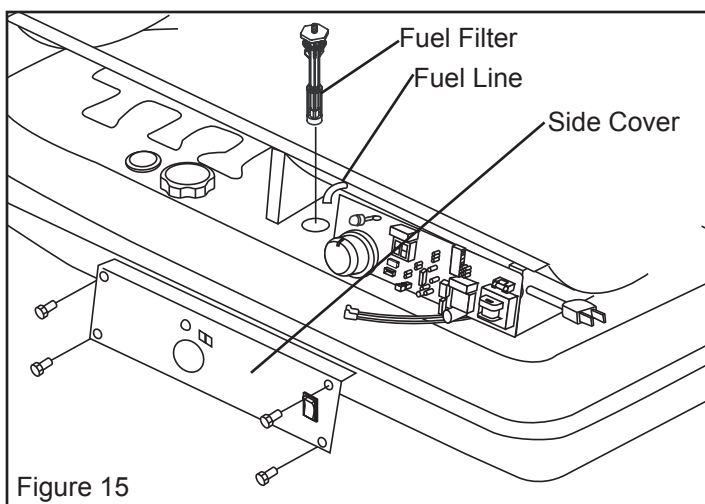

Figure 15

SPARK PLUG:

Clean and re-gap every 600 hours of operation, or replace as needed. After removing the spark plug, clean the terminals with a wire brush. Re-gap the terminals to 0.140" (3.5mm) See Figure 16.

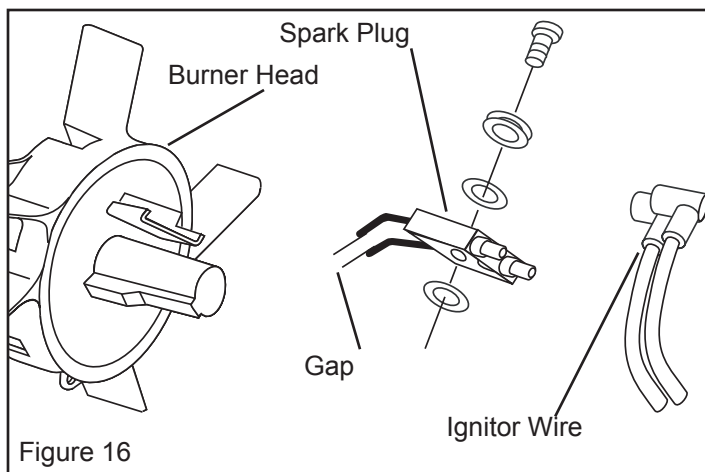

Figure 16

PHOTOCELL:

The photocell should be cleaned using a cotton swab dipped in alcohol or water at least once per heating season, or more depending on conditions. See Figure 17.

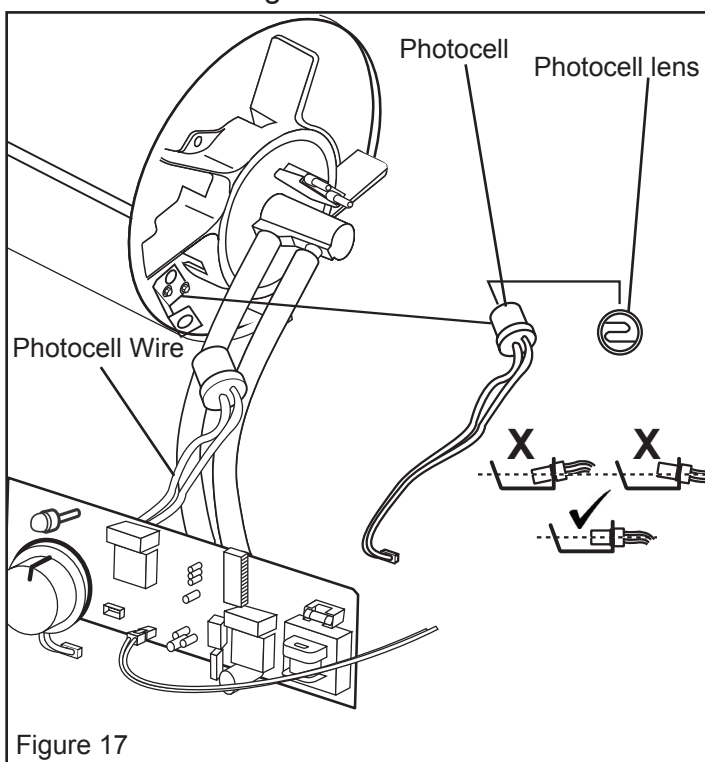

Figure 17

Maintenance

PUMP PRESSURE:

While heater is operating, turn adjusting screw clockwise to increase, counter-clockwise to decrease pressure. Correct pump pressure is as follows:

Model Number	Pump Pressure
FF 45	3.0 PSI / 0.21 BAR
FF 70	3.7 PSI / 0.26 BAR
FF 125	4.5 PSI / 0.31 BAR
FF 175	6.5 PSI / 0.45 BAR
FF 215	8.0 PSI / 0.55 BAR

Tolerance $\pm 10\%$

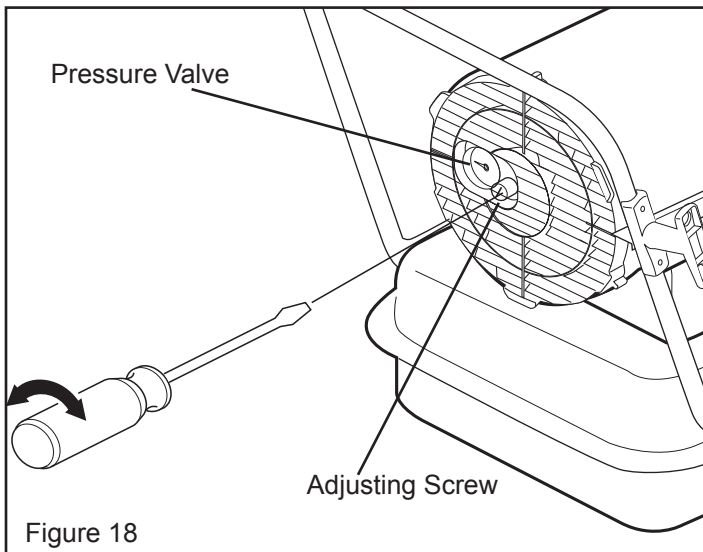

Figure 18

NOZZLES:

Nozzles should be cleaned or replaced at least once per heating season. Contaminated fuel could make this necessary immediately. To clean dirt from nozzle, blow compressed air through nozzle front. It may be necessary to soak the nozzle in paraffin to loosen any dirt particles.

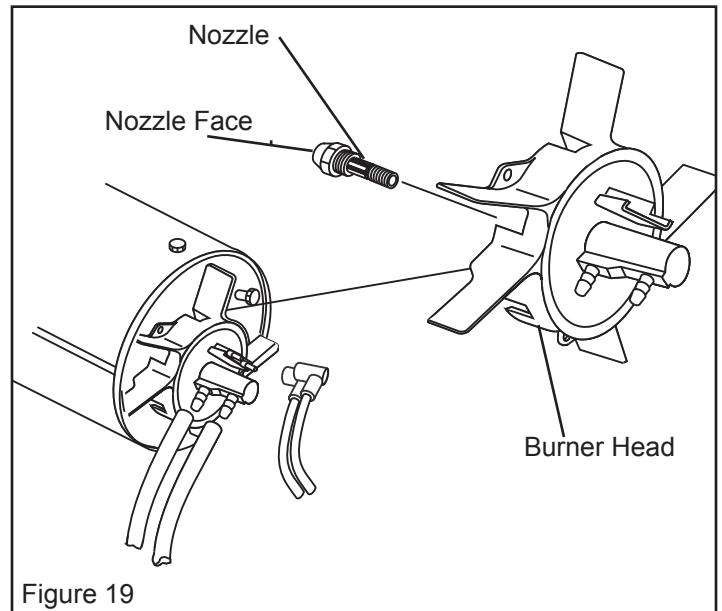

Figure 19

Wiring Diagram

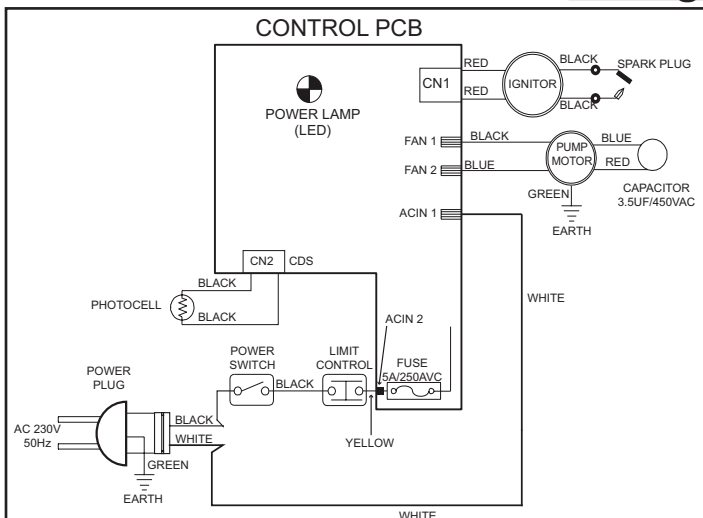

Figure 20: FF 45

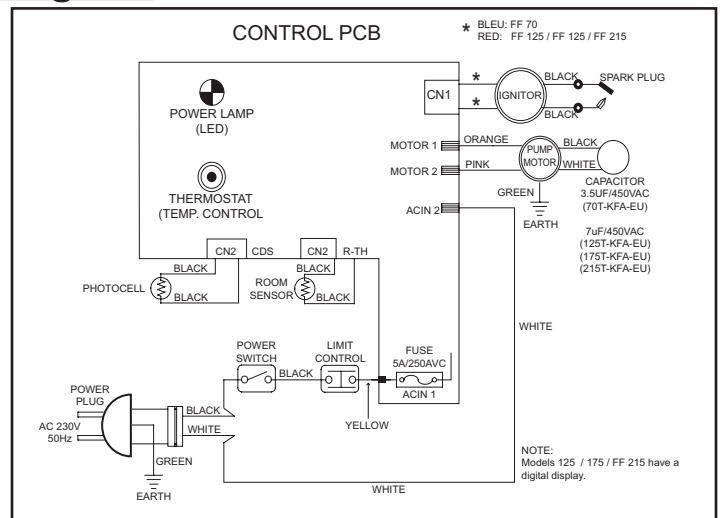
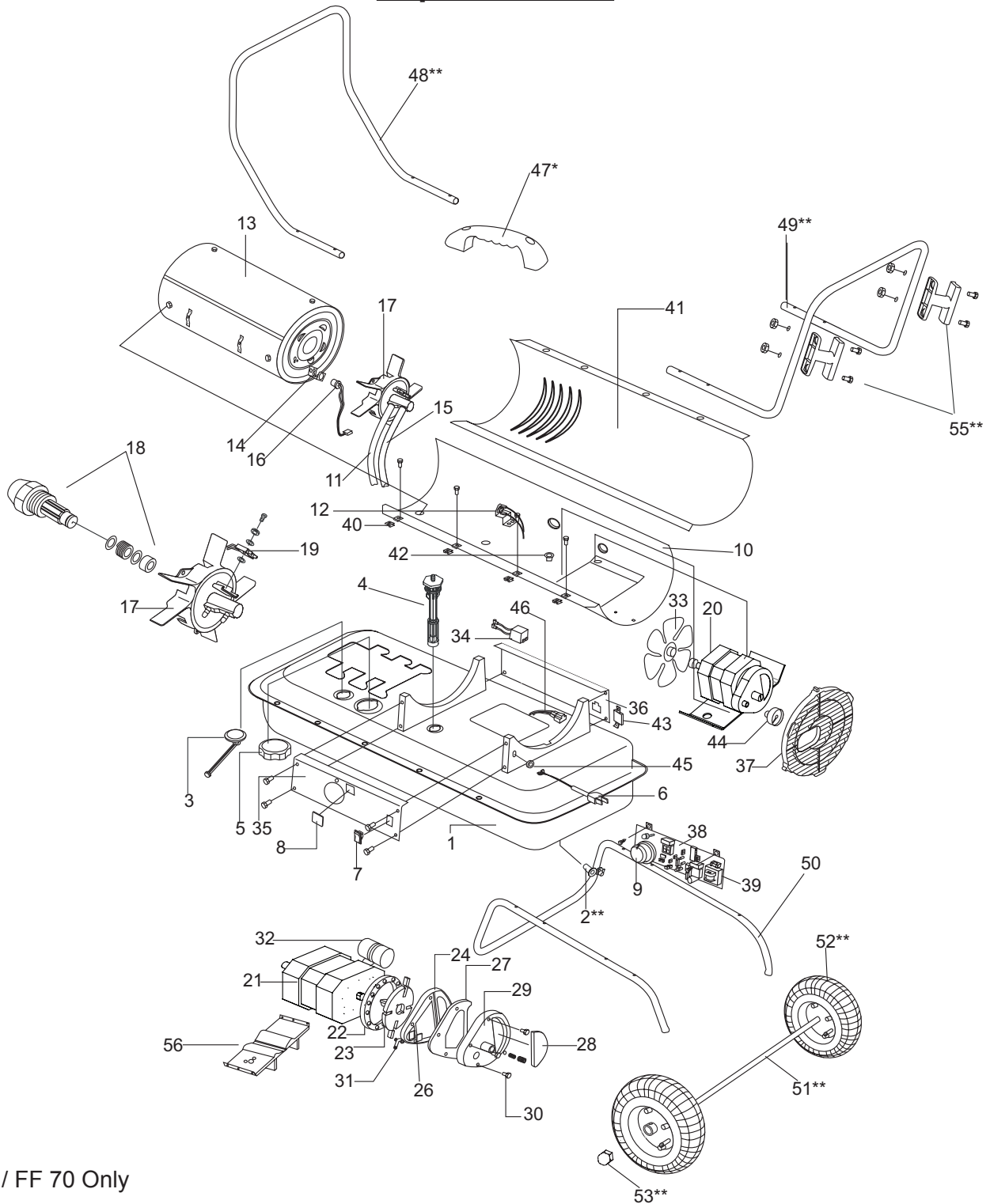

Figure 21: FF 70 / FF 125 / FF 175 / FF 215

Troubleshooting Guide

Problem	Possible Cause	Solution
Heater Ignites, but main PCB shuts off after a short period of time. Lamp flickers and LED display shows "E1".	<ol style="list-style-type: none"> 1. Incorrect pump pressure. 2. Dirty input, output or lint filter. 3. Dirty fuel filter. 4. Nozzle is dirty. 5. Photocell lens is dirty. 6. Photocell not installed properly. 7. Photocell is defective. 8. Improper electrical connection between main PCB and photocell. 	<ol style="list-style-type: none"> 1. Adjust pump pressure. 2. Clean / replace air or lint filter. 3. Clean / replace fuel filter. 4. Clean / replace Nozzle. 5. Clean / replace photocell. 6. Adjust photocell position 7. Replace photocell 8. Check wiring connections (see wiring diagrams on page 11).
Heater will not operate or motor runs for a short time. Lamp flickers and LED display shows "E1".	<ol style="list-style-type: none"> 1. No paraffin in the fuel tank. 2. Incorrect pump pressure. 3. Corroded spark plug or incorrect plug gap. 4. Dirty fuel filter. 5. Dirty nozzle. 6. Moisture in fuel tank. 7. Improper electrical connection between transformer and circuit board. 8. Ignitor wire not connected to spark plug. 9. Defective ignitor. 	<ol style="list-style-type: none"> 1. Fill tank with fresh paraffin. 2. Adjust pump pressure. 3. Clean / replace spark plug. 4. Clean / replace fuel filter. 5. Clean / replace nozzle. 6. Rinse fuel tank with clean, fresh paraffin. 7. Inspect all electrical connections. (See wiring diagrams on page 11.) 8. Re-attach ignitor wire to spark plug. 9. Replace ignitor.
Fan does not operate when heater is plugged in and power switch is in the "ON" position. The lamp is flickering or and LED display shows "E1" or "E2".	<ol style="list-style-type: none"> 1. Thermostat is set too low (does not apply to HK45 model). 2. Broken electrical connection between main PCB and motor. 	<ol style="list-style-type: none"> 1. Rotate thermostat to a higher setting 2. Inspect all electrical connections (see wiring diagrams on page 11).
Lamp is flickering and LED display shows "E3".	<ol style="list-style-type: none"> 1. Thermostat switch has failed. 	<ol style="list-style-type: none"> 1. Replace thermostat switch (see Wiring diagrams on page 11).
Poor combustion and / or excess soot production.	<ol style="list-style-type: none"> 1. Dirty input, output or lint filter. 2. Dirty fuel filter. 3. Poor quality of fuel. 4. PSI is too high or too low. 	<ol style="list-style-type: none"> 1. Clean / replace air or lint filter. 2. Clean / replace fuel filter. 3. Flush fuel tank and refuel heater. 4. Use proper pressure.
Heater does not turn on and the lamp is not lit.	<ol style="list-style-type: none"> 1. Temperature limit sensor has overheated. 2. No electrical power. 3. Fuse is blown. 4. Improper electrical connection between temperature limit sensor and circuit board. 	<ol style="list-style-type: none"> 1. Push power switch to "OFF" and allow heater to cool for 10 minutes. Restart heater. 2. Check power cords for proper connection and test the power supply. 3. Check / replace the fuse. 4. Inspect all electrical connections (see wiring diagrams on page 11).

Exploded View



*FF 45 / FF 70 Only

**FF 125 / FF 175 / FF 215 Only



NEVER LEAVE HEATER UNATTENDED WHILE BURNING OR WHILE CONNECTED TO A POWER SOURCE

Parts List

▲WARNING ALWAYS contact the manufacturer of this heater before replacing any parts other than those specified or recommended in the servicing instructions.

Item No.	Description	Part Number for Models:				
		FF 45	FF 70	FF 125	FF 175	FF 215
1	Fuel Tank Assembly	70-002-0100	70-002-0100	70-002-0200	70-002-0300	70-002-0300
2	Drain Plug	—	—	70-002-0105	70-002-0105	70-002-0105
3	Fuel Gauge Assembly	70-007-0110	70-007-0115	70-007-0210	70-007-0210	70-007-0215
4	Fuel Filter Assembly	70-003-0100	70-003-0100	70-003-0200	70-003-0200	70-003-0200
5	Fuel Cap	70-006-0120	70-006-0120	70-006-0120	70-006-0120	70-006-0120
6	Power Cord	70-034-0270	70-034-0270	70-034-0270	70-034-0270	70-034-0270
7	Power Switch	70-038-0110	70-038-0110	70-038-0110	70-038-0110	70-038-0110
8	Window Display	—	—	70-040-0100	70-040-0100	70-040-0100
9	Thermostat Control Knob	—	70-031-0100	70-031-0100	70-031-0100	70-031-0100
10	Lower Shell	—	—	—	—	—
11	Air Line	70-035-0100	70-035-0200	70-035-0300	70-035-0400	70-035-0500
12	Thermostat Limit Control	70-019-0100	70-019-0100	70-019-0205	70-019-0100	70-019-0200
13	Combustion Chamber Assembly	70-011-0100	70-011-0200	70-011-0300	70-011-0400	70-011-0500
14	Photocell Bracket	70-010-0101	70-010-0101	70-010-0101	70-010-0101	70-010-0101
15	Fuel Line	70-036-0100	70-036-0200	70-036-0300	70-036-0400	70-036-0500
16	Photocell Assembly	70-016-0100	70-016-0100	70-016-0100	70-016-0100	70-016-0100
17	Burner Head Assembly	70-014-0101	70-014-0101	70-014-0301	70-014-0401	70-014-0401
18	Nozzle Kit	70-015-0100	70-015-0200	70-015-0300	70-015-0400	70-015-0500
19	Spark Plug Kit	70-052-0100	70-052-0100	70-052-0200	70-052-0200	70-052-0200
20	Motor and Pump Assembly	70-020-0570	70-020-0570	70-020-0575	70-020-0580	70-028-0580
21	Motor	70-021-0501	70-021-0501	70-021-0511	70-021-0521	70-021-0521
22	Pump Body	70-020-0101	70-020-0101	70-020-0101	70-020-0101	70-020-0401
23	Rotor Kit	70-022-0100	70-022-0100	70-022-0200	70-022-0200	70-022-0200
24	End Pump Cover	70-020-0102	70-020-0102	70-020-0102	70-020-0102	70-020-0102
25	Filter Kit	70-054-0100	70-054-0100	70-054-0100	70-054-0100	70-054-0100
26	Lint Filter	70-054-0102	70-054-0102	70-054-0102	70-054-0102	70-054-0102
27	Output Filter	70-023-0100	70-023-0100	70-023-0100	70-023-0100	70-023-0100
28	Intake Filter	70-054-0101	70-054-0101	70-054-0101	70-054-0101	70-054-0101
29	End Filter Cover	70-020-0103	70-020-0103	70-020-0103	70-020-0103	70-020-0103
30	Plug/Pump Adjustment Kit	70-055-0100	70-055-0100	70-055-0100	70-055-0100	70-055-0100
31	Nipple	70-014-0104	70-014-0104	70-014-0104	70-014-0104	70-014-0104
32	Capacitor	70-020-0130	70-020-0130	70-020-0220	70-020-0220	70-020-0221
33	Fan Assembly	70-024-0100	70-024-0200	70-024-0300	70-024-0400	70-024-0400
34	Ignitor	70-037-0120	70-037-0120	70-037-0320	70-037-0320	70-037-0320
35	Right Side Cover	70-008-0100	70-008-0200	70-008-0300	70-008-0400	70-008-0450
36	Left Side Cover	70-009-0100	70-009-0100	70-009-0200	70-009-0300	70-009-0300
37	Fan Guard	70-016-0700	70-016-0700	70-016-0200	70-016-0200	70-016-0220
38	Main PCB Assembly	70-027-0160	70-027-0160	70-027-0220	70-027-0320	70-027-0320
39	Fuse	70-027-0120	70-027-0120	70-027-0120	70-027-0120	70-027-0120
40	Clip Nut	70-001-0105	70-001-0105	70-001-0105	70-001-0105	70-001-0105
41	Upper Shell	—	—	—	—	—
42	Storage Box	—	—	70-053-0100	70-053-0100	70-053-0100
43	Bushing Grommet	70-017-0100	70-017-0100	70-017-0100	70-017-0100	70-017-0100
44	Air Pressure Gauge	70-025-0100	70-025-0100	70-025-0100	70-025-0100	70-025-0100
45	Cord Bushing	70-033-0100	70-033-0100	70-033-0200	70-033-0200	70-033-0200
46	Handle	70-001-0103	70-001-0103	—	—	—
47	Front Handle	—	—	70-042-0100	70-042-0200	70-042-0200
48	Rear Handle	—	—	70-043-0100	70-043-0200	70-043-0200
49	Wheel Support Frame	—	—	70-041-0101	70-041-0201	70-041-0201
50	Wheel Axle	—	—	70-041-0115	70-041-0205	70-041-0205
51	Wheel (Pneumatic)	—	—	70-041-0150	70-041-0150	70-041-0150
52	Wheel Nut	—	—	70-041-0550	70-041-0550	70-041-0550
53	Hardware Kit	70-056-0100	70-056-0100	70-056-0210	70-056-0210	70-056-0210
55	Cord Wrap	70-032-0100	70-032-0100	70-032-0200	70-032-0200	70-032-0200
56	Motor Supporter	70-020-0600	70-020-0600	70-020-0610	70-020-0610	70-020-0610

