



User's Manual & Operating Instructions

PT 70-SS / PT 125-SS DIESEL FIRED RADIANT HEATER



PT 70-SS



PT 125-SS

ORIGINAL INSTRUCTIONS

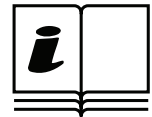

CONSUMER: READ AND SAVE THESE INSTRUCTIONS

⚠ DANGER **GENERAL HAZARD WARNING:**
READ AND UNDERSTAND ALL OF THE INSTRUCTIONS IN THIS MANUAL BEFORE ASSEMBLING, STARTING, OR SERVICING THE HEATER. Be sure to comply with the instructions and warnings provided with this heater. Failure to comply can result in fire or explosion that can cause property loss, bodily injury, or loss of life. Only persons who can follow and understand these instructions should operate or service this heater.

⚠ DANGER **NOT FOR USE IN RESIDENTIAL LIVING AREAS OR IN ENCLOSED SPACES WITHOUT ADEQUATE VENTILATION. TO BE USED IN WELL VENTILATED COMMERCIAL / INDUSTRIAL OCCUPANCIES.** This is an unvented portable heater that uses air (Oxygen) from within the area in which it is used. Failure to provide adequate combustion and ventilation air will result in asphyxiation, carbon monoxide poisoning, bodily injury or death. Refer to "Ventilation" on Page 7.

⚠ WARNING This appliance shall be installed in accordance with the rules in force, and used only in sufficiently ventilated space. Consult instructions before installation and use of this appliance.

© 2018 Lavorwash Australia Pty Ltd
7/76 Rushdale Street, Knoxfield, Vic. 3180

Table Of Contents

Safety Information.....	1-2	Maintenance.....	9-12
Features and Specifications.....	3	Troubleshooting Guide.....	13
PT 70-SS Assembly.....	4	Wiring Diagram.....	14
PT 125-SS Assembly.....	5-6	Exploded View.....	15, 17
Ventilation.....	7	Parts List.....	15-16, 18
Operation.....	7-8		

Safety Information

▲WARNING **FIRE, BURN, INHALATION AND EXPLOSION HAZARD.** Keep combustibles such as; building materials, paper or cardboard a safe distance away from the heater as recommended by these instructions. Never use the heater in spaces which contain products such as; gasoline, solvents, paint thinners, dust particles, volatile or airborne combustibles or any unknown chemicals. This is an unvented portable heater. It uses air (Oxygen) from the area in which it is used. Adequate combustion and ventilation air must be provided. Refer to "Ventilation" on page 7. Bulk fuel storage should be a minimum of 25 feet from heater.

▲WARNING **DO NOT OPERATE THIS HEATER UNTIL YOU HAVE READ AND THOROUGHLY UNDERSTAND THESE SAFETY AND OPERATING INSTRUCTIONS.**

Failure to comply with the precautions and instructions provided with this heater can result in death, serious bodily injury, property loss or damage from the hazards of fire, soot production, explosions, burns, asphyxiation or carbon monoxide poisoning. Only persons who can read and understand these instructions should use or service this heater.

▲WARNING **DO NOT START THE HEATER WHEN EXCESS OIL HAS ACCUMULATED.**

▲WARNING **DO NOT START THE HEATER WHEN THE CHAMBER IS HOT.**

THE INSTALLATION OF THIS HEATER SHALL COMPLY WITH THE REGULATIONS OF THE AUTHORITIES HAVING JURISDICTION.

This appliance can be used by children aged from 8 years and above and persons with reduced physical, sensory or mental capabilities or lack of experience or and knowledge if they have been given supervision or instruction concerning use of the appliance in a safe way and understand the hazards involved. Children shall not play with the appliance. Cleaning and user maintenance shall not be made by children without supervision.

i **Look for this icon throughout the manual for helpful tips on how to assemble, use and clean your SS Heater.**

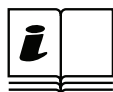

Read The Instruction manual: When this symbol is marked on a product, it means that the instruction manual must be read.



WARNING! Never touch heater until heater has cooled off.

Safety Information

▲ WARNING RISK OF INDOOR AIR POLLUTION!

The products described in this manual are Paraffin/Diesel direct-fired, forced air heaters. Paraffin/Diesel forced air heaters are primarily intended for use for temporary heating of buildings under construction, alteration or repair. Direct-fired means that all of the combustion products of the heater enter the heated space. This appliance is rated at 98% combustion efficiency, but does produce small amounts of carbon monoxide.

▲ WARNING CARBON MONOXIDE POISONING MAY LEAD TO DEATH!

Carbon monoxide is toxic. Humans can tolerate only small amounts of carbon monoxide and so precautions should be taken to provide proper ventilation. Failure to provide proper ventilation in accordance with the instructions in this manual can result in death.

People with breathing problems should consult a physician before using this heater.

Early signs of carbon monoxide poisoning resemble the flu. Symptoms of improper ventilation / carbon monoxide poisoning are:

- Headache • Dizziness • Nausea • Dry Mouth**
- Sore Throat • Burning of Nose and Eyes**

If you experience any of these symptoms: **GET FRESH AIR AT ONCE!** Have your heater serviced and check for proper ventilation. Some people are more affected by carbon monoxide than others. These include: pregnant women, those with heart or lung problems, anemia or those under the influence of alcohol or at high altitudes.

Use this heater in only well ventilated areas! Provide at least a three square foot (2,800 cm²) opening of outside air for every 29 kW / Hr heater rating. Refer to “Ventilation” on page 7 for further instructions.

▲ WARNING RISK OF ELECTRIC SHOCK!

ALWAYS use only the electrical power (voltage and frequency) specified on the model plate of the heater. ALWAYS use only properly grounded socket and properly rated extension cables. ALWAYS unplug the heater when not in use. ALWAYS install the heater so that it is not directly exposed to water spray, rain, dripping water, or wind. If the supply cord is damaged, it must be replaced by a special cord or assemble available from the manufacturer, its service agent or similarly qualified persons in order to avoid a hazard

▲ WARNING RISK OF BURNS, FIRE AND EXPLOSION!

NEVER use fuels such as gasoline, benzene, paint thinners or other oil compounds in this heater. NEVER refill the heater’s fuel tank while the heater is operating or still hot. This heater is EXTREMELY HOT while in operation. NEVER block air inlet (rear) or air outlet (front). NEVER use duct work in front or rear of heater. NEVER move or handle heater while still hot. NEVER transport heater with fuel in tank. NEVER use with an external fuel tank.

▲ WARNING CAUTION! HOT WHILE IN OPERATION. DO NOT TOUCH. KEEP CHILDREN, ANIMALS, CLOTHING AND COMBUSTIBLES AWAY FROM HEATER.

Keep all combustible materials away from this heater.

Minimum Clearance From Combustibles		
	PT 70-SS	PT 125-SS
Top	1.2 m	1.2 m
Sides	1.2 m	1.2 m
Front	2.4 m	2.4 m

ALWAYS locate heater on a stable and level surface. If your heater is equipped with a thermostat, once it is plugged in, it can start at anytime in accordance with the thermostat setting.

Specifications

Model #	PT 70-SS	PT 125-SS
Rating: kW/Hr	20	36.6
Fuel Consumption: L/Hr	2.0	3.4
Fuel Tank Capacity: L	15	53
Max Operating Hours	7	20
Volts: AC/Hz	240VAC / 50Hz	240VAC / 50Hz
Heating Area m ²	533	952.5
Weight (kg)	16.5	38.1
Noise (dBA)	70	75

Specifications subject to change without notice.

Features

PT 70-SS

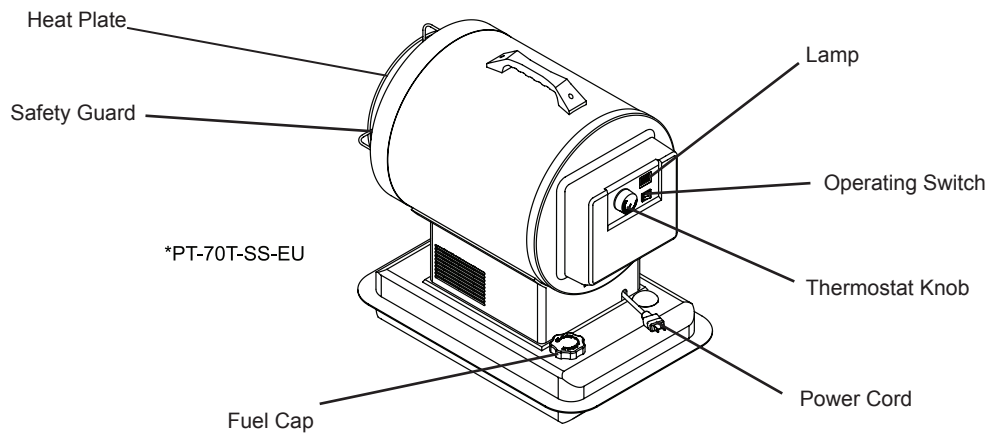

Figure 1

PT 125-SS

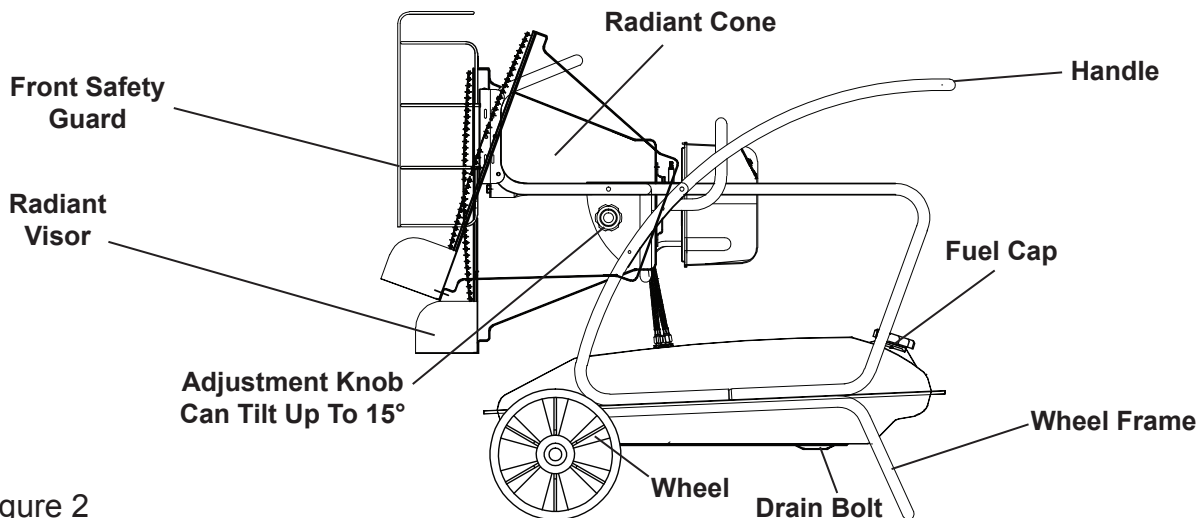

Figure 2

Assembly Instructions

PT 70-SS

- Remove the heater and all packaging materials from the shipping carton.

Note: Save the box and packaging materials for future storage.

What's In The Box

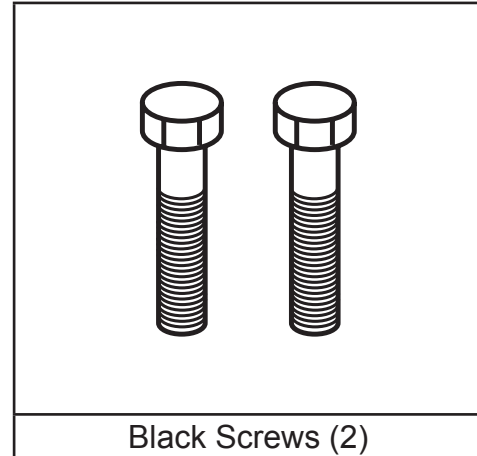
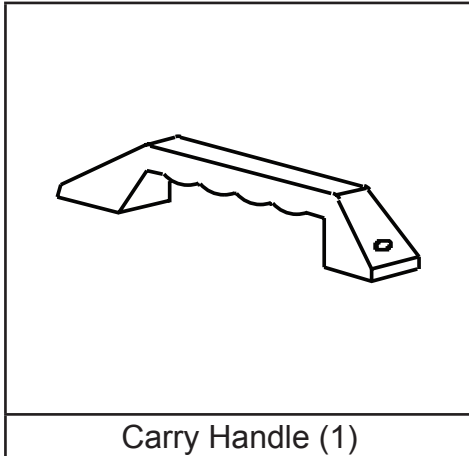

Carry Handle Assembly

1. Align holes in the upper housing with the 2 holes in the handle as shown in Figure 3.
2. Insert screws and tighten firmly.

Tools Needed:

- Phillips Head Screw Driver

i **Attach the handle while still in the box for easier unpacking. (See Figure 4)**

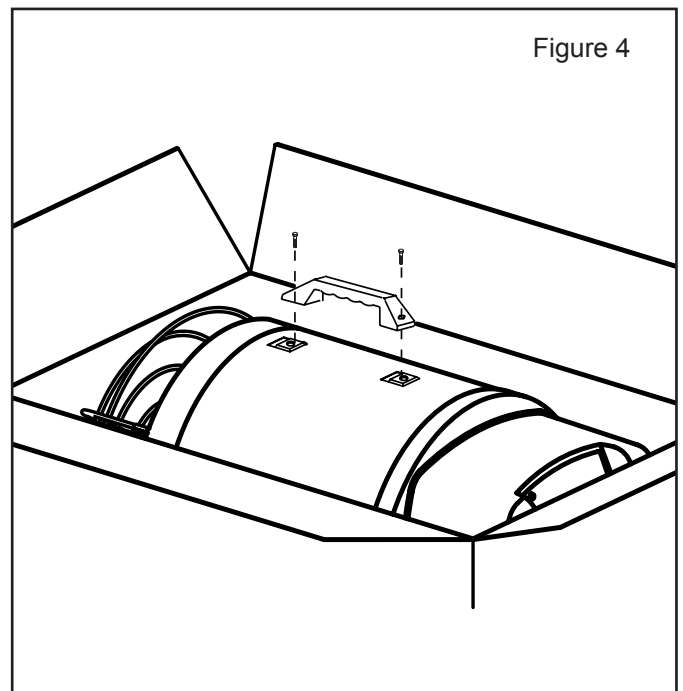
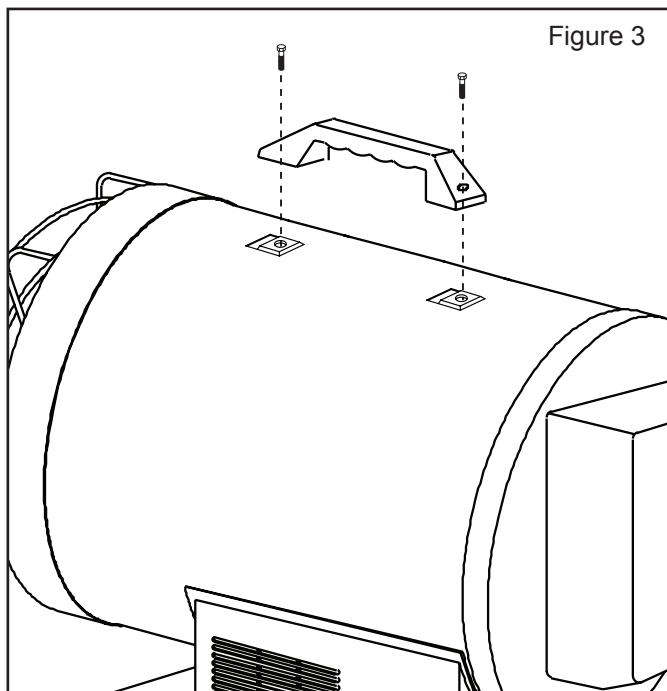

Assembly Instructions

- Remove the heater and all packaging materials from the shipping carton.

Tools Needed:

- Phillips Head Screw Driver
- 8 mm open end wrench

i *Tip: Be sure to remove the axle from the side of the Styrofoam packaging.*

i *Tip: Use a power screwdriver and locking wrench for easier assembly.*

What's In The Box

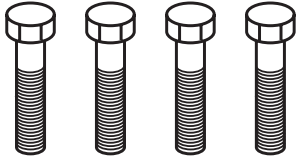
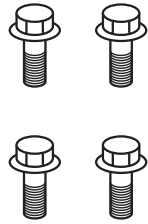
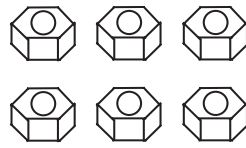
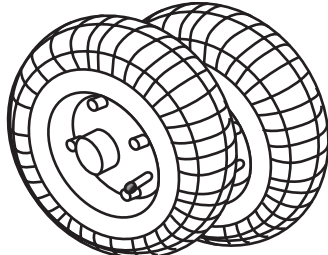
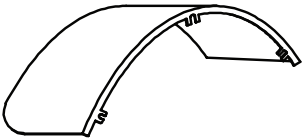
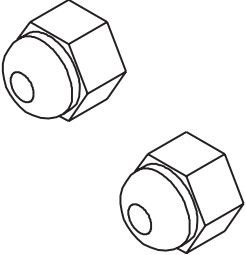
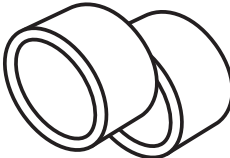
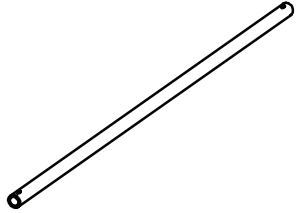
			
<p>Long Screws (6)</p>	<p>Short Screws (4)</p>	<p>8 mm Nuts (6)</p>	<p>Wheels (2)</p>
			
<p>Visors</p>	<p>19 mm Axle Nuts (2)</p>	<p>Spacers (2)</p>	<p>Axle (1)</p>

Safety Guards (Top, Front)

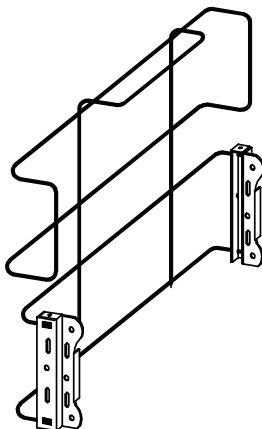

Wheel Frame

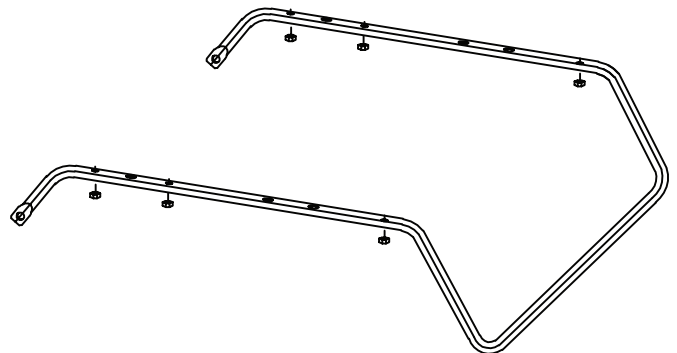

Assembly Instructions

PT 125-SS

Assembly

1. Slide axle through Wheel Frame and attach wheels, washers and nuts.

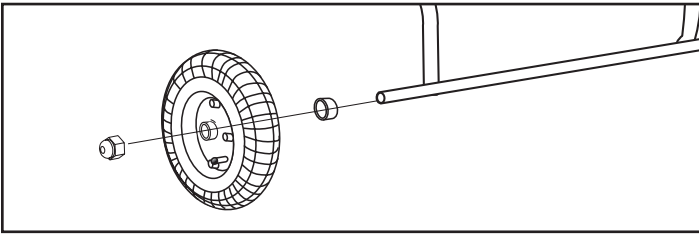

2. Place main structure on wheel frame and fasten with long screws provided.

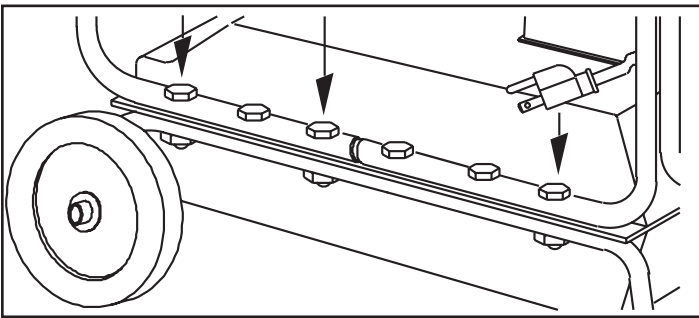

3. Attach safety guard to front of heater with screws provided.

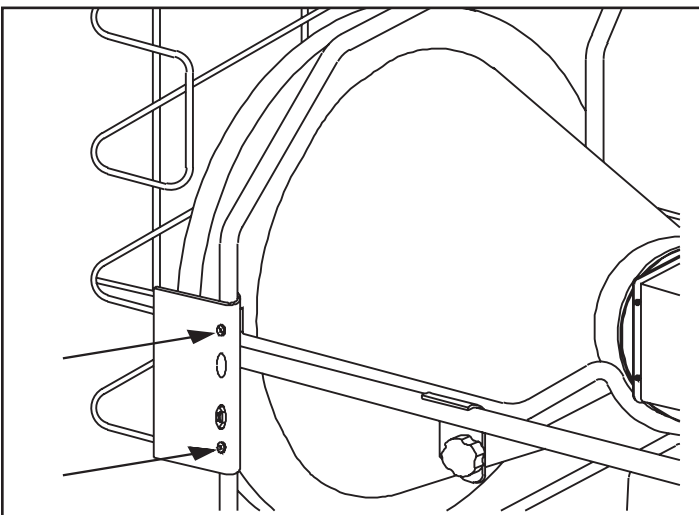

4. Attach Radiant Visors to the top and bottom rear of the Radiant Cone Assembly using extra screws included.

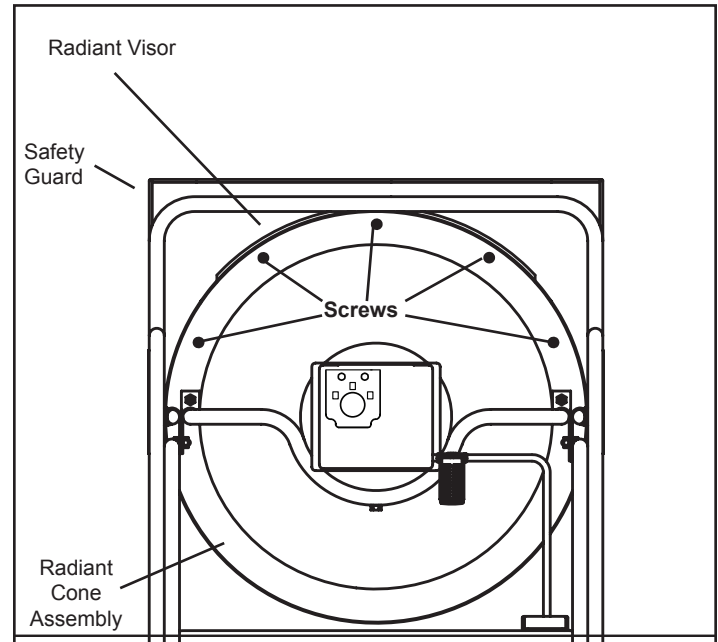

5. Attach top safety guard using the two outer-most extra screws on the top of the radiant cone (See photo).

Note: Save the box and packaging materials for future storage.

Operation

Fueling The Heater:

Paraffin

For optimal performance of this heater, it is strongly suggested that Paraffin be used. Paraffin has been refined to virtually eliminate contaminants, such as sulfur, which can cause a rotten egg odor during the operation of the heater. Using diesel fuel can cause excess soot production. Do not use Bio-Diesel as this fuel will damage your heater’s seals and filter.

▲ DANGER NEVER REFUEL THIS HEATER WHILE IT IS HOT OR OPERATING. FIRE OR EXPLOSION COULD RESULT.

▲ CAUTION NEVER FILL THE FUEL TANK INDOORS. ALWAYS FILL THE TANK OUTDOORS. BE SURE THAT THE HEATER IS ON LEVEL GROUND WHEN FUELING, AND NEVER OVERFILL THE TANK.

▲ WARNING DO NOT USE GASOLINE OR CRANKCASE DRAININGS.

- NEVER use fuel such as, benzene, alcohol, white glass, camp stove fuel, paint thinners, or other oil compounds in this heater. THESE ARE VOLATILE FUELS THAT CAN CAUSE A FIRE OR EXPLOSION.
- NEVER store Paraffin in the living space. Paraffin should be stored in a well ventilated area outside the living area.
- NEVER store Paraffin in direct sunlight or near a source of heat.
- NEVER use Paraffin that has been stored from one season to the next. Paraffin deteriorates over time. OLD PARAFFIN WILL NOT BURN PROPERLY IN THIS HEATER.

NOTE: Paraffin should only be stored in a blue container that is clearly marked “Paraffin.” Never store Paraffin in a red container. Red is associated with gasoline.

Ventilation:

- Risk of indoor air pollution and Carbon Monoxide Poisoning. Use heater only in well ventilated areas.
- Refer to Safety Information on pages 1-2 for information about Carbon Monoxide Poisoning.
- ALWAYS provide a fresh air opening in the heated space of at least 2,800 cm² (3 sq. ft) for each 29 kW / Hr. of heater output. Provide a larger opening if more heaters are being used.

▲ DANGER CARBON MONOXIDE POISONING MAY LEAD TO DEATH!

As an example, a PT 125-SS will require:

- A two car garage door open 16 cm or
- A single car garage open 22 cm or
- Two (2) 82 cm windows open 38.5 cm

Minimum Ventilation Opening Needed	
PT 70-SS	PT 125-SS
1950 cm ²	3484 cm ²

▲ WARNING This appliance is designed to operate safely at a minimum ambient temperature of -20° C.

▲ WARNING Use caution when servicing in wet areas. Disconnect power from the power mains and keep all electrical components from becoming wet. Only a qualified technician should service the heater

▲ WARNING A qualified technician is required to install, adjust and where necessary; convert this heater for use with other fuel types.

Operation: PT 70-SS / PT 125-SS

Starting the Heater: (Ignition)

1. Fill the tank with Kerosene or other approved fuel.
2. Replace fuel cap and tighten firmly.
3. Connect the heater to a three prong (grounded) power source. You must use a three prong (grounded) extension cord that is at least 1.8 meters long and is a minimum of 14 AWG rating.

NOTE: On first ignition or after refueling, you may hear a grinding sound just before ignition. This is the fuel pump removing the air from the fuel line. Your heater will start up within seconds. If it does not start repeat start-up procedures with fuel gauge reading at least 1/2 tank.

NOTE: The electrical components of these heaters are protected by a fuse mounted in the PC board. If the heater fails to ignite, check this fuse first and replace if necessary. Also check the power source to be sure the proper voltage is being provided to the heater.

1. Complete steps 1-3 above.
2. Push the power switch to the "ON" position. The power indicator lamp will light and heater will ignite. (See Figure 5)

Stopping the Heater: (Cool Down)

1. Turn the power switch to the "OFF" position. Combustion will stop and the Cooling Cycle will begin.

- PT 70-SS: approx. 7 mins
- PT 125-SS: approx 3 mins

When the Cooling Cycle is complete the fan will stop running and it will be safe to unplug the heater.

NOTE: Unplugging the heater before the Cooling Cycle has been completed may cause overheating, possible damage to the heater and heat plate.

Restarting the Heater:

1. Wait ten seconds after Cooling Cycle has been completed.
2. Follow all start-up procedures above.

⚠ WARNING DO NOT disconnect heater from power source before cooling cycle has been completed.

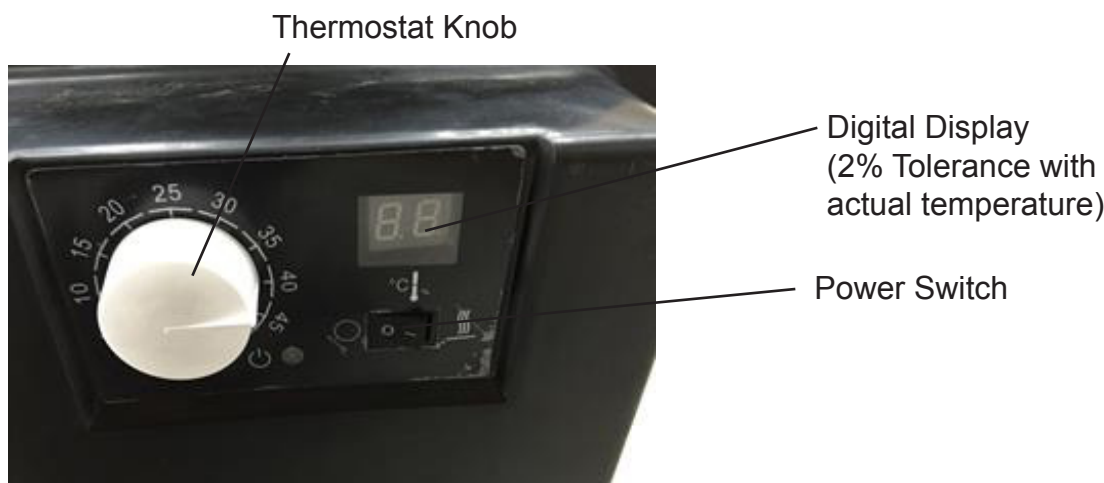

Maintenance - PT 70-SS

Long Term Storage:

1. Unscrew the fuel cap.
2. Using an approved siphon (Figure 11.1), remove the Paraffin or diesel.
3. Using a small amount of Paraffin or diesel, rinse and swirl the fuel inside the fuel tank

NOTE: NEVER MIX WATER WITH FUEL. It will cause rust inside the tank.

4. Empty the tank completely.

IMPORTANT: Never store leftover Paraffin between seasons, using old fuel can damage heater.

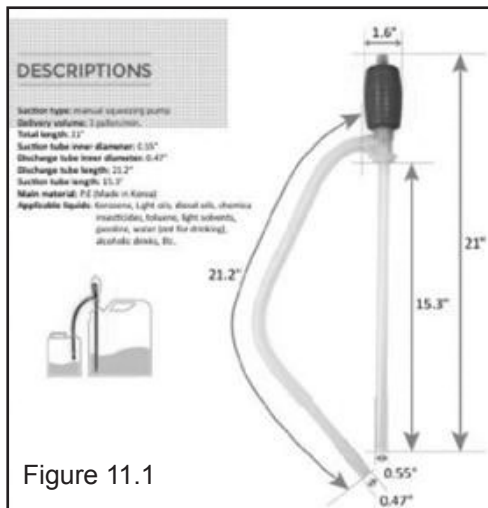

Figure 11.1

Store Heater in a dry, well ventilated area.

- Be sure that the storage area is free of dust and corrosive vapors. Repack the heater in the original packaging and keep user's manual in an easily accessible place.

Service:

⚠ WARNING Never service heater while it is plugged in or hot!

DO NOT TAMPER WITH THE UNIT. HAVE AN EXPERIENCED SERVICEMAN MAKE ANY NECESSARY ADJUSTMENT OR REPAIRS.

We suggest following a maintenance schedule as follows:

TIP: Follow the long term storage instructions to flush the tank.

FUEL / FUEL TANK:

Flush tank every 200 hours of operation or as needed. DO NOT flush with water, use fresh Paraffin only.

SPARK PLUG:

Clean and re-gap every 600 hours of operation or replace as needed. After removing the Spark Plug, clean the terminals with a wire brush. Re-gap the terminals to 0.140" (3.5mm). (See Figure 11.2)

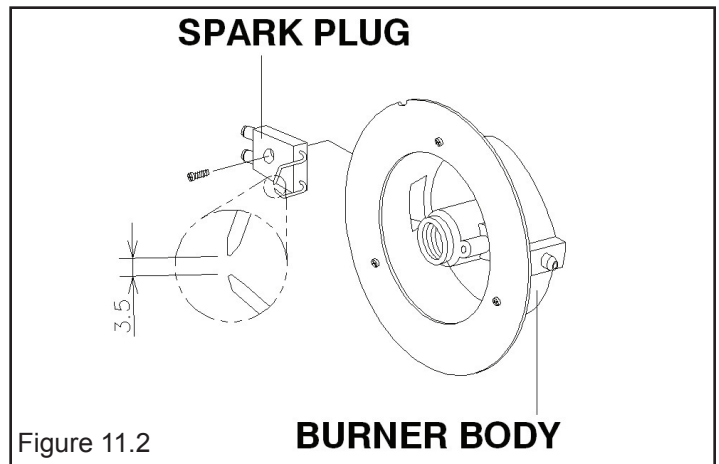

Figure 11.2

FAN BLADES:

The fan blades should be cleaned at least once per heating season, depending on conditions. Remove all accumulated dust and dirt with a burst of condensed air. (See Figure 12)

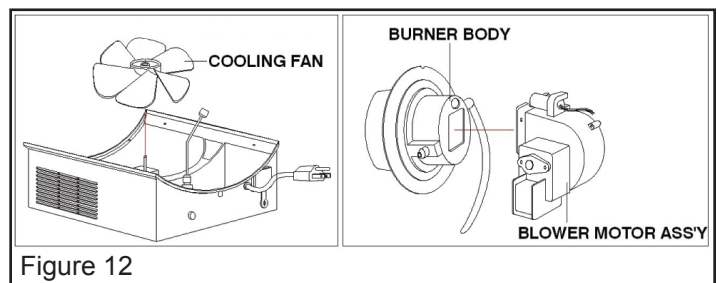

Figure 12

Maintenance - PT 70-SS

Service (Continued):

NOZZLES:

Nozzles should be cleaned or replaced at least once per heating season. Contaminated fuel could make this necessary immediately. To clean dirt from nozzle, blow compressed air through nozzle front. It may be necessary to soak nozzle in clean paraffin or diesel to help loosen any particles. (See Figure 13)

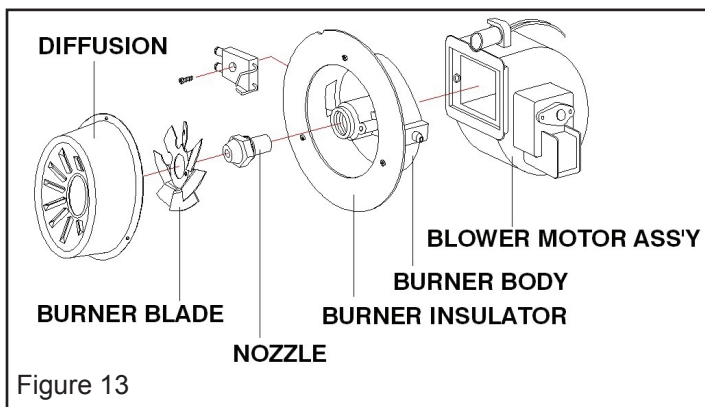

PHOTOCELL:

The photocell should be cleaned at least once per heating season or more depending on conditions. Use a cotton swab and water or alcohol to clean the lens of the photocell. Be certain to reinstall the photocell in proper position as shown below. (See Figure 14)

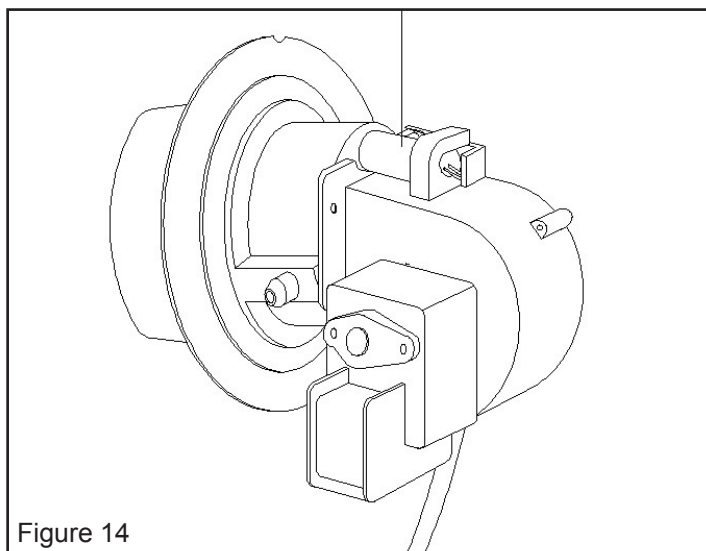

FILTERS:

The fuel filter and oil filter should be cleaned at least twice per heating season by rinsing it in clean paraffin or diesel. Contaminated or old fuel could make cleaning necessary immediately. (See Figure 15)

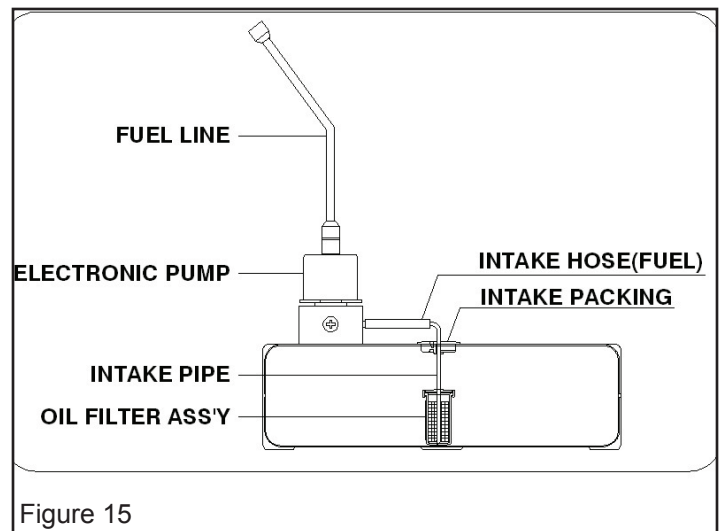

Maintenance - PT 125-SS

Long Term Storage:

1. Unscrew the drain bolt and drain all fuel.
(See Figure 17)
2. Using a small amount of Paraffin or diesel, rinse and swirl the fuel inside the fuel tank.

NOTE: NEVER MIX WATER WITH FUEL. It will cause rust inside the tank.

3. Empty the tank completely.

IMPORTANT: Never store leftover Paraffin between seasons, using old fuel can damage heater.

Store Heater in a dry, well ventilated area.

- Be sure that the storage area is free of dust and corrosive vapors. Repack the heater in the original packaging and keep user's manual in an easily accessible place.

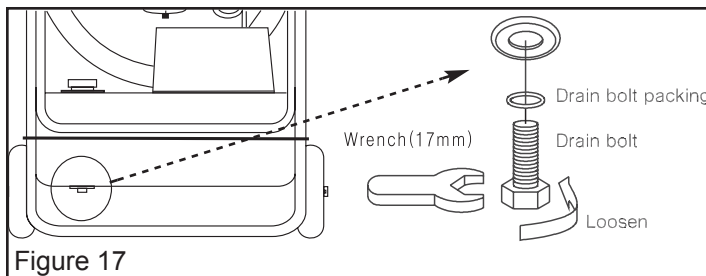

Figure 17

Service:

⚠ WARNING Never service heater while it is plugged in or hot!

DO NOT TAMPER WITH THE UNIT. HAVE AN EXPERIENCED SERVICEMAN MAKE ANY NECESSARY ADJUSTMENT OR REPAIRS.

We suggest following a maintenance schedule as follows:

FUEL / FUEL TANK:

***i* TIP: Follow the long term storage instructions to flush the tank.**

Flush tank every 200 hours of operation or as needed. DO NOT flush with water, use fresh Paraffin only.

SPARK PLUG:

Clean and re-gap every 600 hours of operation, or replace as needed After removing the Spark Plug, clean the terminals with a wire brush. (See Figure 18)

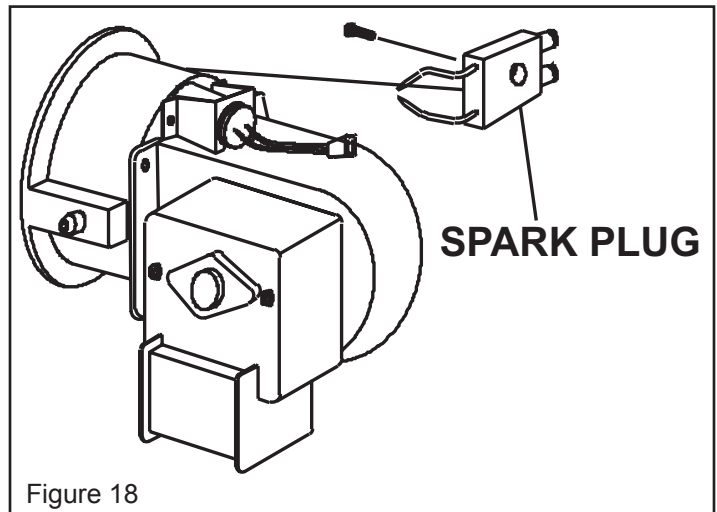

Figure 18

NOZZLES:

Nozzles should be cleaned or replaced at least once per heating season. Contaminated fuel could make this necessary immediately. To clean dirt from nozzle, blow compressed air through nozzle front. It may be necessary to soak nozzle in clean diesel to help loosen any particles (Figure 19).

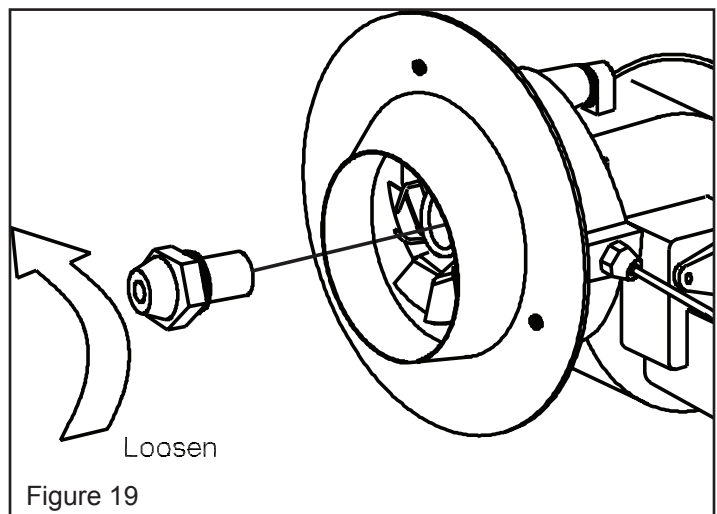

Figure 19

Maintenance - PT 125-SS

Service (Continued):

PHOTOCELL:

The photocell should be cleaned at least once per heating season or more depending on conditions. Use a cotton swab and water or alcohol to clean the lens of the photocell. (See Figure 21)

Be certain to reinstall the photocell in proper position as shown below. (See Figure 20)

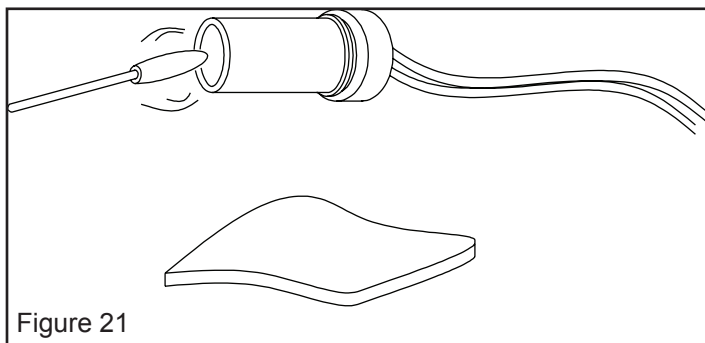
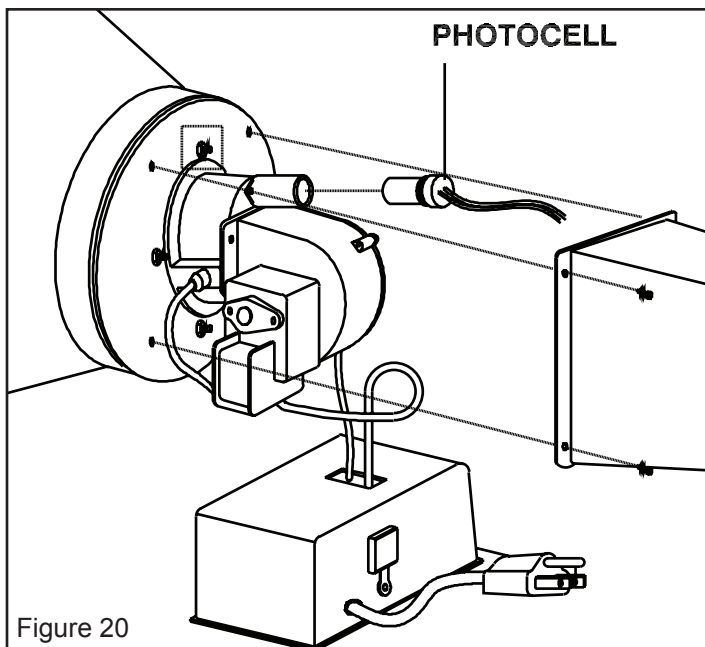

FILTERS:

The fuel filter and oil filter should be cleaned at least twice per heating season by rinsing it in clean paraffin or diesel. Contaminated or old fuel could make cleaning necessary immediately. (See Figure 22)

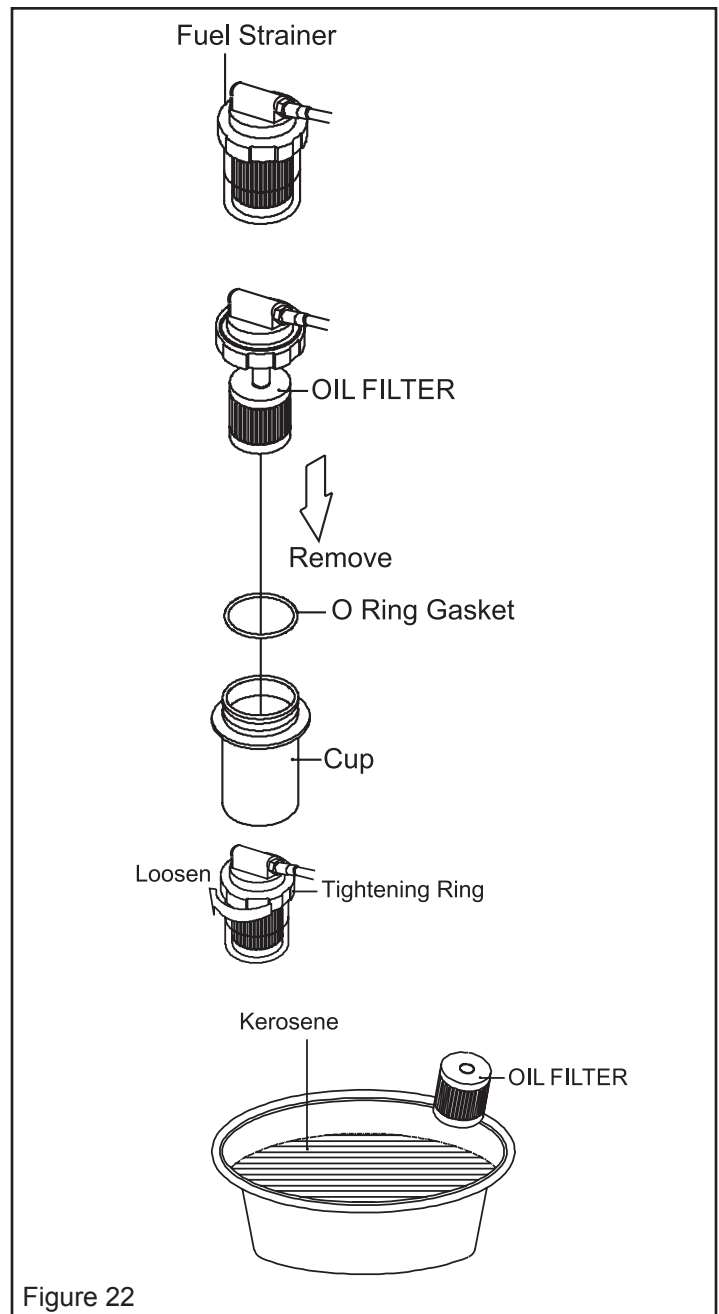

Troubleshooting Guide

Problem	Possible Cause	Solution
Heater fires, but shuts down after a short period of time.	<ol style="list-style-type: none"> 1. Dirty Fuel Filter. 2. Nozzle Dirty. 3. Photocell Dirty. 4. Photocell not installed properly. 5. Photocell Defective . 6. Improper electrical connection between Circuit Board and Photocell. 7. Cooling Fan is obstructed 	<ol style="list-style-type: none"> 1. Clean/replace Fuel Filter. 2. Clean/replace Nozzle 3. Clean/replace Photocell . 4. Adjust Photocell position. 5. Replace Photocell. 6. Check wiring connections (See Wiring Diagrams, Page 14). 7. Check to be sure cooling fan is not obstructed.
Heater will not operate, or motor runs for short time.	<ol style="list-style-type: none"> 1. No paraffin/ diesel in fuel tank. 2. Corroded Spark Plug or incorrect plug gap. 3. Dirty Fuel Filter. 4. Dirty Nozzle. 5. Moisture in Fuel/Fuel Tank. 6. Improper electrical connection between Transformer and Circuit Board. 7. Transformer Wires not connected to Spark Plug. 8. Defective Transformer. 	<ol style="list-style-type: none"> 1. Fill tank with fresh paraffin/ diesel. 2. Clean/replace Spark Plug. 3. Clean/replace Fuel Filter. 4. Clean/replace Nozzle. 5. Rinse out fuel tank with clean fresh paraffin/ diesel. 6. Inspect all electrical connections. (See Wiring Diagrams, Page 14). 7. Re-attach Transformer wires to Spark Plug. 8. Replace Transformer.
Fan does not operate when heater is plugged in and Operating Switch is in the "ON" position.	<ol style="list-style-type: none"> 1. Broken electrical connection between Circuit Board and motor. 2. Not enough amps available to power heater. 	<ol style="list-style-type: none"> 1. Inspect all electrical connections on Wiring Diagrams (Page 14). 2. Use a new extension cord or try another electrical socket.
Heater makes grinding noise.	<ol style="list-style-type: none"> 1. Air in fuel pump. 	<ol style="list-style-type: none"> 1. Sound will stop after 3 seconds. If grinding sound continues, add fuel to tank.
Heater does not turn on and the lamp is not lit.	<ol style="list-style-type: none"> 1. Temperature limit sensor has overheated. 2. No electrical power. 3. Fuse break down. 4. Improper electrical connection between Temperature Limit Sensor and Circuit Board. 	<ol style="list-style-type: none"> 1. Push Operating Switch to "OFF" and allow heater to cool for 5 minutes. Push Operating Switch back to "ON". 2. Check power cord and extension cord to insure of proper connection. Test power supply. 3. Check/replace Fuse. 4. Inspect all electrical connections. (See Wiring Diagrams, Page 14).
Poor combustion and / or soot production.	<ol style="list-style-type: none"> 1. Pump Pressure. 2. Poor fuel quality. 	<ol style="list-style-type: none"> 1. Be sure pump pressure is adjusted correctly. 2. Be sure paraffin/ diesel is not old or contaminated.

Wiring Diagrams

PT 70-SS

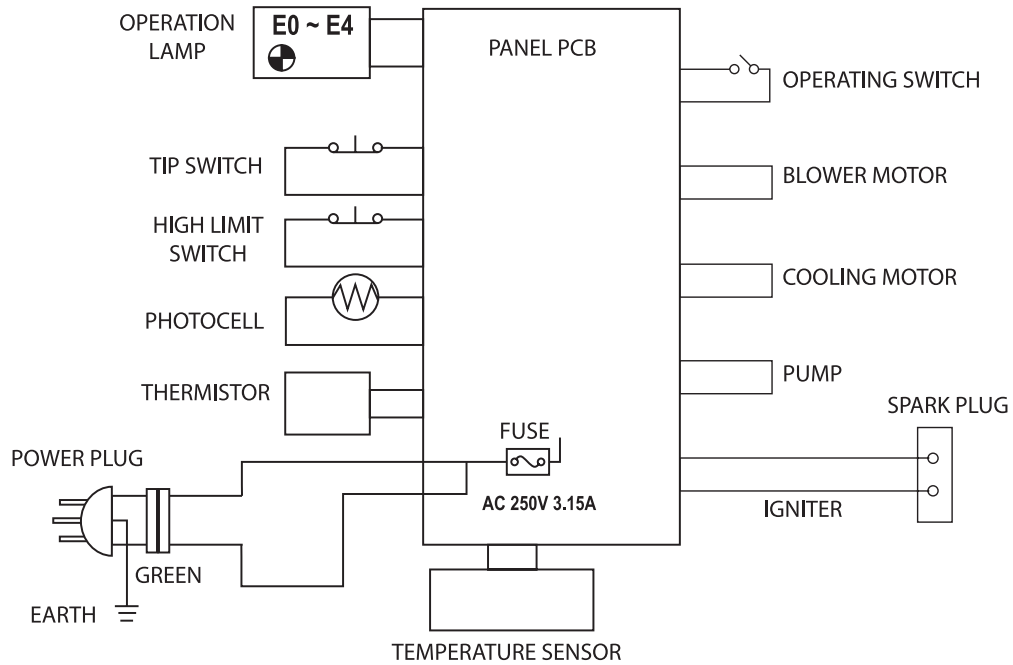

Figure 23

PT 125-SS

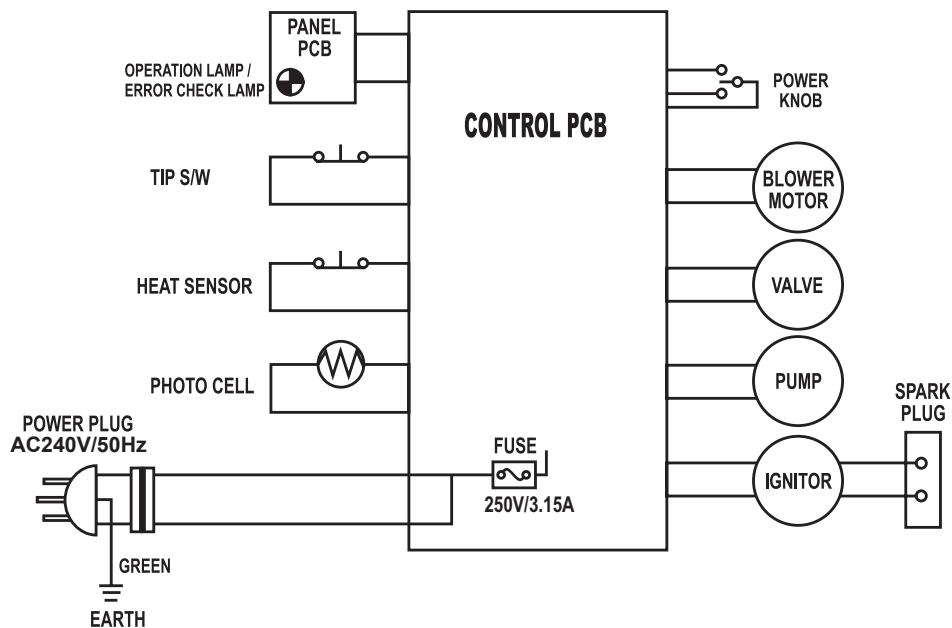
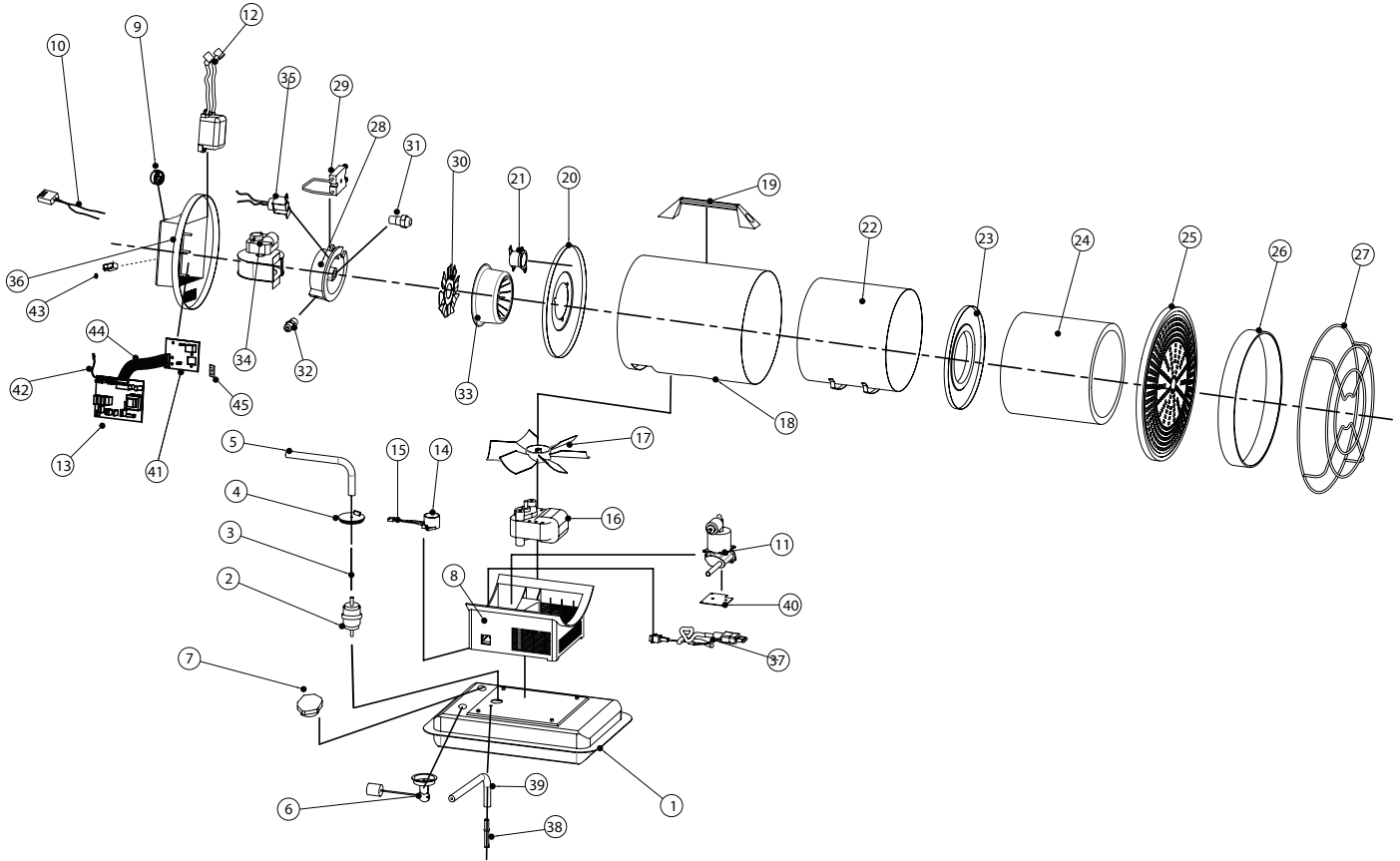

Figure 24

Exploded View

PT 70-SS



PARTS LIST

#	Part	Previous	Current
1	Fuel Tank Assembly	75-011-0350	01.01.75.007010691
2	Fuel Filter	75-023-0285	75-023-0285
3	Fuel Pipe	75-023-0345	01.03.71.015010074
4	Fuel Packing	75-023-0355	01.03.75.007010042
5	Fuel Hose	75-024-0700	75-024-0740
6	Fuel Gauge	75-022-0210	01.04.75.007010071
7	Fuel cap	70-006-0135	70-006-0140
8	Cooling Fan Housing	N/A	75-011-0685
9	Control Knob	75-012-0110	01.02.75.107020060
10	Power Switch wire Assembly	75-012-0220	01.04.75.007010087
11	Electronic Pump	75-027-0261	01.01.75.207020001
12	Igniter	75-075-0200	01.04.70.104520033
13	Main PCB with Thermostat	75-025-0455	01.04.75.207020002
14	Tip Over Sensor	75-051-0200	01.04.75.007010149
15	Tip over Sensor Wire Assembly	75-051-0260	01.04.75.007010086

PARTS LIST

#	Part	Previous	Current
16	Motor	75-045-0270	01.04.75.607020260
17	Plastic Fan Blade	75-047-0200	01.02.75.007010054
18	Outer Shell	75-011-1110	01.01.75.007020694
19	Handle	75-001-0060	01.02.75.007010055
20	Burner Body Supporter	75-011-1100	01.01.75.007010346
21	Temperature Limit Control	75-040-0110	01.04.75.007020685
22	Chamber Insulator	75-035-0800	01.01.75.007010222
23	Shell Insulator	75-035-0820	01.01.75.007010220
24	Ceramic Fiber	75-035-0830	01.03.75.007010038
25	Heat Plate	75-012-0600	01.01.75.007010690
26	Shell Ring	75-011-0650	01.01.75.007010206
27	Safety Guard	75-012-0310	01.01.75.007010205
28	Burner Body	75-036-0185	01.01.75.007020686
29	Spark Plug	75-075-0200	01.04.75.007010078
30	Burner Blade	75-036-0120	01.01.75.007010700
31	Nozzle	75-036-0435	01.01.75.007020215
32	Nipple	75-040-0610	01.01.75.007010203
33	Diffusion cap	75-036-0500	01.01.75.007010209
34	Blower Motor	75-045-0205	01.04.75.607020261
35	Photocell	75-038-0200	01.04.75.007010083
36	Back Cover	75-013-0106	01.02.75.207020001
37	Power Cord	75-032-0185	01.04.75.507020153
38	Return Pipe	75-055-0100	01.01.75.007010204
39	Return Hose	75-055-0100	01.01.75.007010204
40	Pump Bracket	75-027-0255	01.01.75.007010195
41	Display PCB	75-013-0150	01.04.75.107020155
42	Thermistor	75-026-0100	01.04.70.007010019
43	Power Switch	75-012-0100	01.04.75.007010088
44	PCB cable	Connected to Display Board	01.04.75.107020156
45	Sub PCB	N/A	N/A
-	Back Panel (not shown)	New in 2017	75-011-0690
-	Pump Connector (not shown)	New in 2017	75-027-0630
-	Inlet Tube Assembly (not shown)	New in 2017	75-024-0725
-	Hose Clamp (not shown)	New in 2017	75-001-0505

Exploded View - PT 125-SS

▲WARNING ALWAYS contact the manufacturer of this heater before replacing any parts other than those specified or recommended in the servicing instructions.

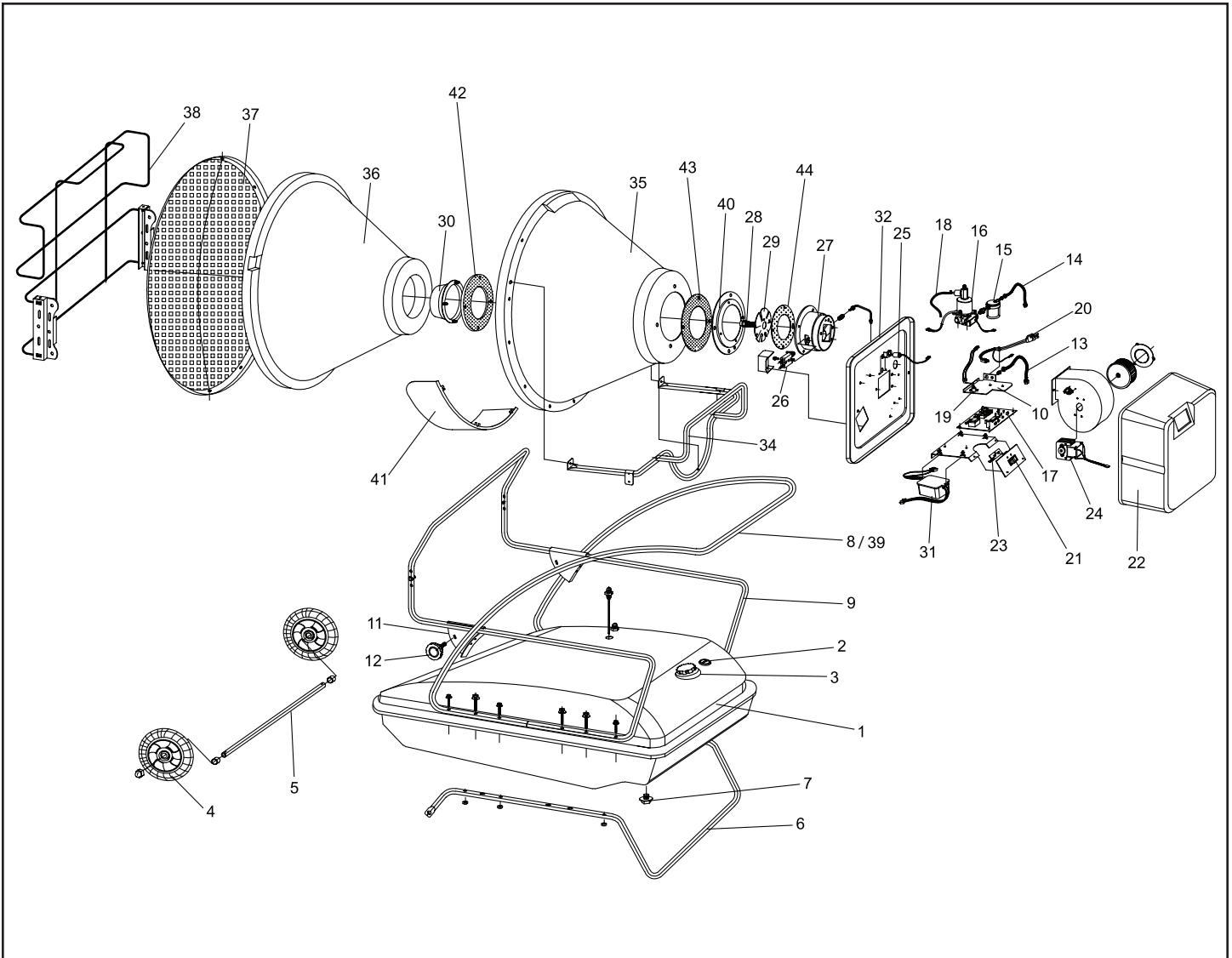

Parts List: PT 125-SS

#	Part	Previous	Current
1	Fuel Tank Assembly	72-001-0200	01.01.72.012510632
2	Fuel Gauge Assembly	72-022-0130	01.04.72.012510105
3	Fuel Tank Cap Assembly	72-035-0615	70-006-0140
4	Wheel	72-041-1400	01.03.90.003610031
5	Axle	72-041-0200	01.01.72.012510253
6	Wheel Frame	72-042-0120	01.01.72.012510240
7	Drain Bolt	72-002-0220	01.01.72.012510245
8	Transport Handle	72-042-0220	01.01.72.012510238
9	Rear Frame	72-042-0320	01.01.72.012510239
10	Pump Support Plate	72-025-0510	01.01.72.012510232
11	Frame Support	N/A	N/A
12	Height Adjustment Knob	72-042-0500	01.02.72.012510064
13	Return Fuel Line	72-023-0260	01.03.71.015010074
14	Intake Fuel Line	72-023-0260	01.03.72.012510049
15	Fuel Filter Assembly	72-020-0100	01.02.72.012510062
16	Fuel Pump Assembly	72-027-0100	01.01.72.312520263
17	Main PCB and Fuse	72-025-0450	01.04.72.012520685
18	Intake Fuel Hose	72-023-0310	01.03.72.012510050
19	Tip Over Sensor	75-051-0200	01.04.75.007010149
20	Power Cord	72-032-0200	01.04.72.412520247
21	Power Switch	72-012-0100	01.04.72.312520120
22	Back Cover	72-013-0110	01.02.72.012510061
23	Panel sub-PCB	72-014-0105	01.04.72.012510107
24	Blower Motor Assembly	72-045-0100	01.04.72.312520116
25	Photocell Assembly	72-038-0200	01.04.75.007010083
26	Spark Plug	75-075-0200	01.04.75.007010078
27	Burner Body	72-035-0210	01.01.72.012510250
28	Nozzle	72-036-0100	01.01.72.312520264
29	Burner Blade	72-035-0500	01.01.72.012510635
30	Diffusion Cap	72-036-0200	01.01.72.012510248
31	Ignitor	72-025-0120	01.04.70.104520033
32	Burner Support Plate	72-035-0110	01.01.72.012510331
33	Temperature Overheat Sensor (not shown)	72-040-0120	01.04.72.012510104
34	Radiant Cone Support Assembly	72-035-0680	01.01.72.012510237
35	Radiant Cone Assembly	72-035-0610	01.01.72.012510246
36	Ceramic Fiber	72-035-0610	01.03.72.012510043
37	Heat Plate	72-012-0200	01.09.75.007010002
38	Safety Guard	72-012-0200	01.01.72.012510242
39	Front Frame	72-042-0220	01.01.72.012510238
40	Burner Bracket	72-035-0700	01.01.72.012510234
41	Radiant Visor	72-012-0220	01.01.72.012510225
42	Burner Housing Gasket	72-035-0630	01.03.72.012510046
43	Burner Bracket Gasket	72-035-0630	01.03.72.012510045
44	Burner Head Gasket	72-035-0215	01.03.72.012510047

Locating Your Serial Number:

Your serial number can be found on a blue label on the left side cover. For Example: S150100001, where the year of manufacture is represented by the 2 digits immediately following the first letter.

Model #: _____

Serial #: _____

Date of Purchase: _____

