

ⓘ ATTENZIONE: leggere le istruzioni prima dell'utilizzo. ⓘ WARNING: read the instructions carefully before use. ⓘ ATTENTION: lire attentivement les instructions avant l'usage. ⓘ ACHTUNG: die anweisungen bitte vor gebrauch sorgfältig lesen. ⓘ ADVERTENCIA: leer atentamente las advertencias antes el uso de aparato. ⓘ LET OP: vóór gebruik de gebruiksaanwijzing aandachtig lezen. ⓘ ΠΡΟΣΟΧΗ: διαβάστε τις οδηγίες πριν τη χρήση. ⓘ ATENÇÃO: ler atentamente as instruções antes da utilização. ⓘ HUOMIO: lue ohjeet

ennen käyttöä. ⓘ ВНИМАНИЕ: перед использованием прочитайте инструкцию по эксплуатации. ⓘ PAZŃJA: prije upotrebe pročitajte upute. ⓘ POZOR: pred uporabo preberite navodila. ⓘ ВНИМАНИЕ: Прочетете внимателно инструкциите преди употреба ⓘ VIKTIGT! läs anvisningarna före användning. ⓘ ADVARSEL: les bruksanvisningen før bruk. ⓘ تسيمة اقرأ التعليمات قبل الاستخدام. ⓘ POZOR: Pred použitím si prečtete návod.

IDROPULITRICE AD ALTA PRESSIONE pag. 9	IT
HIGH PRESSURE CLEANER pag. 16	EN
NETTOYEUR HAUTE PRESSION page 23	FR
HOCHDRUCKREINIGER Seite 31	DE
(HIDRO)LIMPIADORA DE ALTA PRESIÓN pág. 39	ES
HOGEDRUKREINIGER blz. 46	NL
ΜΗΧΑΝΗΜΑ ΚΑΘΑΡΙΣΜΟΥ ΜΕ ΥΨΗΛΗ ΠΙΕΣΗ blz 53	EL
LAVADORA DE ALTA PRESSÃO pág. 61	PT
KORKEAPAINEPESURI sivu 68	FI
ГИДРООЧИСТИТЕЛЬ ВЫСОКОГО ДАВЛЕНИЯ стр 74	RU
VISOKOTLAČNI VODENI ČISTAČ str. 80	HR
VISOKOTLAČNI VODNI ČISTILNI APARAT str. 87	SL
ВОДОСТРУЕН АПАРАТ ПОД НАЛЯГАНЕ стр. 93	BG
صفحة ماكينة غسيل بالضغط العالي 1-104	AR
BRUKSANVISNING FÖR HÖGTRYCKSTVÄTT sid. 105	SV
BRUKSANVISNING FOR HØYTRYKKS VASKER sid. 112	NO
VYSOKOTLAKÝ ČISTIČ str. 118	CS

COLUMBIA LP
COLUMBIA-R LP

EXPLORER LP
EXPLORER-R LP

HYPER C LP
HYPER-R CR LP



IT DESCRIZIONE DELL'APPARECCHIO **EN DESCRIPTION OF THE MACHINE** **FR DESCRIPTION DU L'APPAREIL** **DE BESCHREIBUNG DES GERÄTS** **ES DESCRIPCIÓN DEL APARATO** **NL TOESTEL UITZICHT** **EL ΣΤΑΝΤΑΡ ΕΞΟΠΛΙΣΜΟΣ** **PT COMPONENTES DO APARELHO** **FI VAKIOVARUSTEET** **RU БАЗОВАЯ КОМПЛЕКТАЦИЯ** **HR SERIJSKA OPREMA** **SL OBSEG DOBAVE** **BG ОПИСАНИЕ НА МАШИНАТА – базова окомплектовка** **SV DE VIKTIGASTE KONTROLLERNA** **NO VIKTIGSTE STYRINGSENHETER** **CS POPIS PŘÍSTROJE**

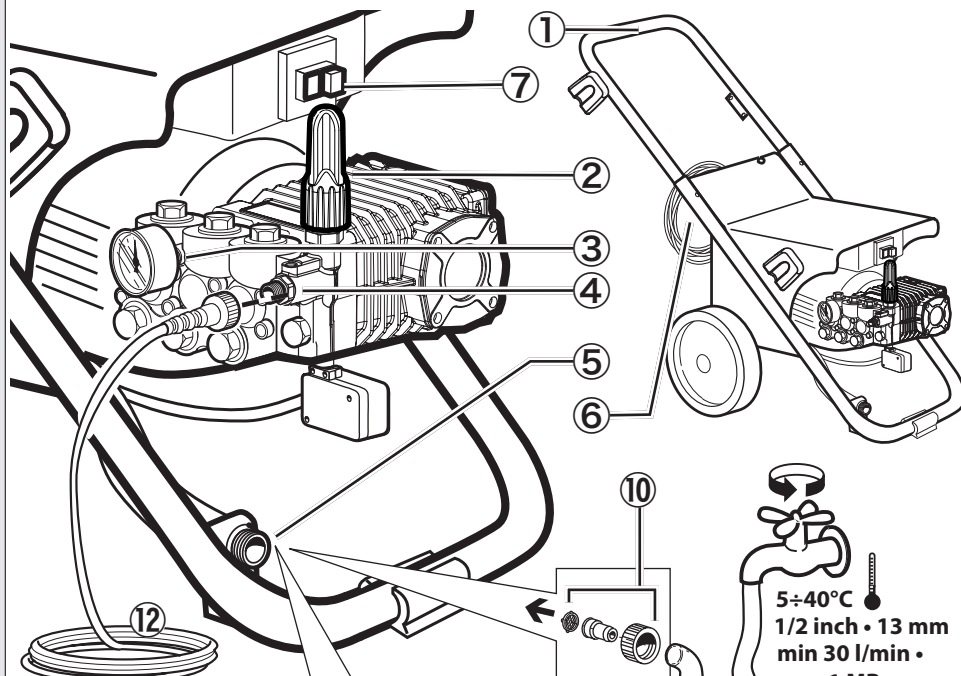

Solo modelli raffreddati ad acqua • only model: water cooling • seul modèle: le refroidissement de l'eau • nur Modell: Wasserkühlung • único modelo: el enfriamiento del agua • enige model: waterkoeling • ainoa malli: vesijäähdytys - Единственная модель: водяное охлаждение • apenas um modelo: resfriamento de água • jedini model: voda za hlađenje • samo model: vodno hlajenje • само модел: водно охлаждане • SV Endast modeller med vattenkyllning • NO Kun vannavkjølte modeller • CS Pouze modely chlazené vodou

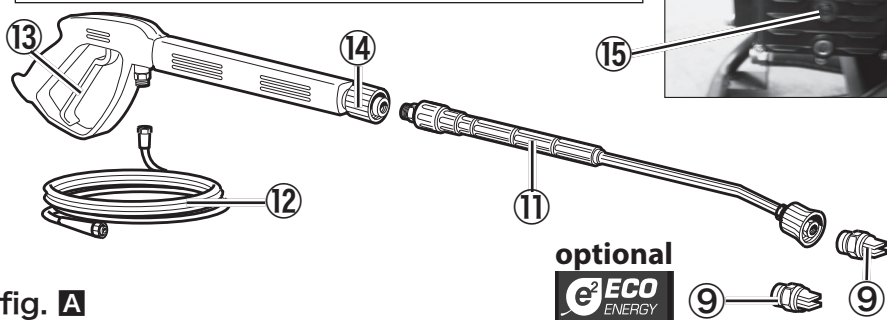
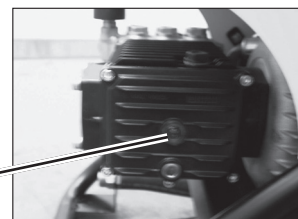

fig. A

optional
E²ECO ENERGY



IT In base al modello si possono verificare delle differenze nella fornitura. **EN** Depending on the model, there are differences in the scopes of delivery. **FR** Suivant le modèle, la fourniture peut varier. **DE** Je nach Modell gibt es Unterschiede im Lieferumfang. **ES** Según el modelo, hay diferencias en el contenido suministrado. **PT** Consoante o modelo, existem diferenças no volume de fornecimento. **FI** Mallien varustetaso vaihtelee, katso kuvaus laatikon kyljestä. **BG** В зависимост от модела има различни обхвати в доставката. **SV** Leveransomfånget varierar allt efter modell. **NO** Alt etter modell kan det være ulike leveringsomfang. **CS** V závislosti na modelu se mohou vyskytnout rozdíly v rozsahu dodávky

fig. B

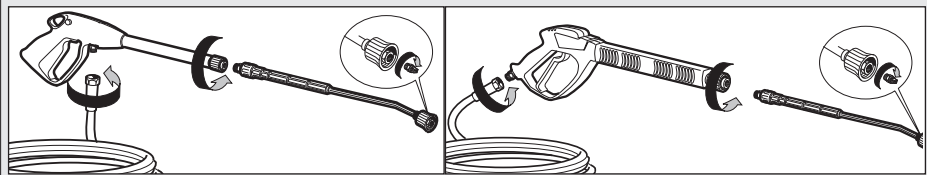

IT

- 1 Maniglia
- 2 Regolazione pressione
- 3 Manometro
- 4 Uscita acqua alta pressione
- 5 Entrata acqua + filtro
- 6 Supporto per cavo elettrico
- 7 Interruttore ON/OFF
- 8 -
- 9 Ugello A.P.
- 10 Raccordo portagomma
- 11 Lancia
- 12 Tubo flessibile alta pressione
- 13 Leva della pistola a spruzzo
- 14 Pistola a spruzzo
- 15 Indicatore livello olio

EN

- 1 Handle
- 2 Pressure control
- 3 Pressure-gauge
- 4 High pressure water outlet
- 5 Water inlet + filter
- 6 Cable holder
- 7 ON/OFF switch
- 8 -
- 9 H.P. nozzle
- 10 Rubber hose fitting
- 11 Lance
- 12 High pressure hose
- 13 Gun trigger lever
- 14 Spray gun
- 15 Oil level display

FR

- 1 Poignée
- 2 Variateur de pression
- 3 Manomètre
- 4 Sortie eau à haute pression
- 5 Entrée d'eau avec filtre
- 6 Porte-câble
- 7 Interrupteur ON/OFF
- 8 -
- 9 Buse H.P.
- 10 Raccord porte-joint
- 11 Lance
- 12 Flexible H.P.
- 13 Gâchette de la poignée-pistolet
- 14 Poignée-pistolet
- 15 Indicateur du niveau d'huile

DE

- 1 Griff
- 2 Druckregulierung
- 3 Manometer
- 4 Wasseraustritt Hochdruck
- 5 Einlauf + filter
- 6 Kabelhalter
- 7 ON/OFF Ausschalter
- 8 -
- 9 Düse A.P.
- 10 Anschluß Gummischlauch
- 11 Lanze
- 12 Hochdruckschlauch
- 13 Hebel der Handspritzpistole
- 14 Handspritzpistole
- 15 Ölstandsanzeige

ES

- 1 Asa
- 2 Mando de regulación de la presión
- 3 Manómetro
- 4 Salida agua alta presión
- 5 Entrada + filtro
- 6 Sujetacables
- 7 Interruptor ON/OFF
- 8 -
- 9 Boquilla A.P.
- 10 Racor del porta manguera
- 11 Lanza
- 12 Tubo alta presión
- 13 Gatillo de la pistola
- 14 Pistola
- 15 Indicador del nivel de aceite

NL

- 1 Hendel
- 2 Drukinstelling
- 3 Manometer
- 4 Hogedruk water uitlaat
- 5 Wateringang met filter
- 6 Kabel houder
- 7 AAN/UIT schakelaar
- 8 -
- 9 H.P. (hogedruk) nozzle
- 10 Rubberslang verbindingstuk
- 11 Lans
- 12 Hogedrukslang
- 13 Pistoelhendel
- 14 Pistoel
- 15 Oliëniveau display

EL

- 1 Χειρολαβή
- 2 Ρύθμιση πίεσης
- 3 Μανόμετρο
- 4 Έξοδος νερού υψηλής πίεσης
- 5 Είσοδος νερού + φίλτρο
- 6 Στήριγμα για ηλεκτρικό καλώδιο
- 7 Διακόπτης ON/OFF
- 8 -
- 9 Ακροφύσια Υ.Π.
- 10 Συνδετικό εύκαμπτου σωλήνα
- 11 Σωλήνας εκτόξευσης
- 12 Εύκαμπτος σωλήνας υψηλής πίεσης
- 13 Μοχλός πιστολιού ψεκασμού
- 14 Πιστόλι ψεκασμού
- 15 Δείκτης στάθμης λαδιού

PT

- 1 Kahva
- 2 Paineensäädin
- 3 Painemittari
- 4 Veden ulostulo korkealla paineella
- 5 Sisääntulo + suodatin
- 6 Johtopidike
- 7 Käyttökytkin PÄÄLLE/POIS
- 8 -
- 9 Suutin
- 10 Letkuliitos
- 11 Suihkuputki
- 12 Korkeapaineletku
- 13 Käsikahvan liipaisin
- 14 Käsikahvan
- 15 Öljytason osoitin

FI

- 1 Ручка для переноса
- 2 Регулятор давления
- 3 Манометр
- 4 Выход
- 5 Вход + фильтр
- 6 Держатель кабеля
- 7 Выключатель
- 8 -
- 9 Форсунка высокого давления
- 10 Держатель шланга
- 11 Гидромонитор
- 12 Шланг высокого давления
- 13 Рычаг
- 14 Ручной пистолет-распылитель
- 15 Индикатор уровня масла

RU

- 1 Manilha
- 2 Regulação de pressão
- 3 Manómetro
- 4 Saída de água de alta pressão
- 5 Entrada água + filtro
- 6 Suporte para cabo eléctrico
- 7 Interruptor lig/des ON/OFF
- 8 -
- 9 Bico injector A.P.
- 10 Junção porta borracha
- 11 Lança
- 12 Tubo alta pressão
- 13 Alavanca da pistola
- 14 Pistola
- 15 Indicador de nível do óleo

HR

- 1 Ručica
- 2 Regulacija pritiska
- 3 Manometar
- 4 Izlaz vode pod visokim pritiskom
- 5 Ulaz vode + filter
- 6 Podloga električnog kabela
- 7 Prekidač ON/OFF
- 8 -
- 9 Prskalica A.P.
- 10 Spojnica nosač gumice
- 11 Usmjerivač
- 12 Fleksibilna cijev pod visokim pritiskom
- 13 Polugica pištolja koji prska
- 14 Pištolj koji prska
- 15 Indikator razine ulja

SL

- 1 Ročaj
- 2 Regulacija tlaka
- 3 Manometer
- 4 Izstop vode z visokim tlakom
- 5 Vstop vode + filter
- 6 Nosilec električnega kabla
- 7 Stikalo ON/OFF
- 8 -
- 9 Visokotlačna šoba
- 10 Priključek gumijaste cevi
- 11 Brizgalna cev
- 12 Visokotlačna gibka cev
- 13 Ročica brizgalke
- 14 Brizgalka
- 15 Indikator nivoja olja

BG

- 1 Дръжка
- 2 Регулятор налягане
- 3 Манометър
- 4 Отвор изходяща вода
- 5 Отвор входяща вода + филтър
- 6 Държач за ел.кабел
- 7 ON/OFF старт бутон
- 8 -
- 9 Водна дюза ВН
- 10 Гум.връзка
- 11 Струйник
- 12 Маркуч ВН
- 13 Спусък пистолет
- 14 Пистолет
- 15 Дисплей ниво на масло

SV

- 1 handtag
- 2 Tryckreglage
- 3 Manometer
- 4 Uttag (vatten)
- 5 Intag + filter (vatten)
- 6 kabelhållare
- 7 ON/OFF-knapp
- 8 -
- 9 Munstycke
- 10 Koppling till gummislang
- 11 Lans
- 12 Tryckslang
- 13 avtryckaren på pistolen
- 14 Pistol
- 15 oljenivå

NO

- 1 Håndtak
- 2 Trykkregulator
- 3 trykkmåleren
- 4 Vannuttak
- 5 Vanninntak + filter
- 6 kabelholderen
- 7 AV/PÅ-bryter
- 8 -
- 9 Dyse
- 10 Gummikobling
- 11 Rengjøringslanse
- 12 Trykkslange
- 13 Avtrekkeren på pistolen
- 14 Pistol
- 15 Oljenivået

CS

- 1 Rukojeť
- 2 Regulátor tlaku
- 3 Tlakoměr
- 4 Výstup vody o vysokém tlaku
- 5 Vstup vody + filtr
- 6 Držák elektrického kabelu
- 7 Vypínač ON/OFF
- 8 -
- 9 Vysokotlaká tryska
- 10 Hadicová přípojka
- 11 Nástavec
- 12 Vysokotlaká flexi hadice
- 13 Páčka stříkací pistole
- 14 Stříkací pistole
- 15 Indikátor hladiny oleje

fig. C

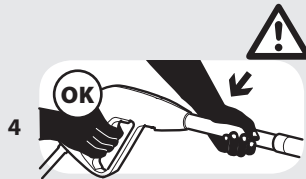
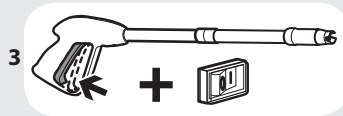
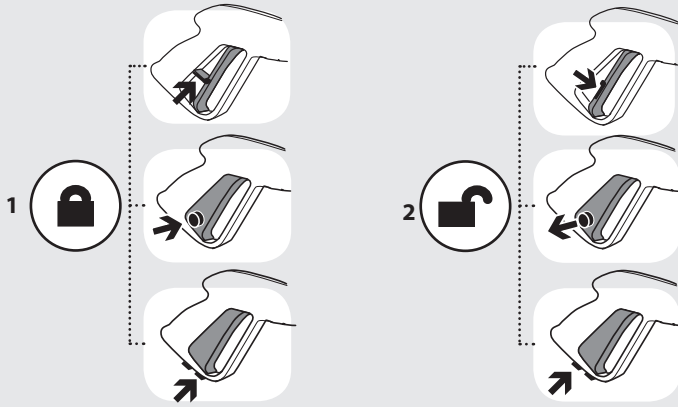

fig. D Optional

IT getto spillo/ventaglio IT alta/bassa pressione
 EN spread pattern/pencil EN high/low pressure FR haute/basse pression
 jet FR jet variable DE vario Hoch/nieder-druck-lanze
 Duese ES chorro regulable ES alta / baja presión NL hoge/lage druk
 NL dunne straal/ PT alta/ baixa pressão EL υψηλή/
 waaivormige straal matalapaine RU высокое/
 EL πιδακας καρφίτσα/ низкое давление HR mlaznica- visoki/niski
 βεντάλια PT jato tlak SL vysokotlaková/
 variabel FI pistemäinen/ nizkotlaková prúdnica BG Високо налягане/ Ниско
 viuhkamainen suihku RU точечная/ веерообразная струя SV sluten/
 струя HR mlaznica-fini mlaz/raspršivač SL i glasti/pahljačasti curek vode BG Настройка на водната струя SV sluten/
 spridd NO samlet stråle/ viftestråle. CS úzký/široký paprsek

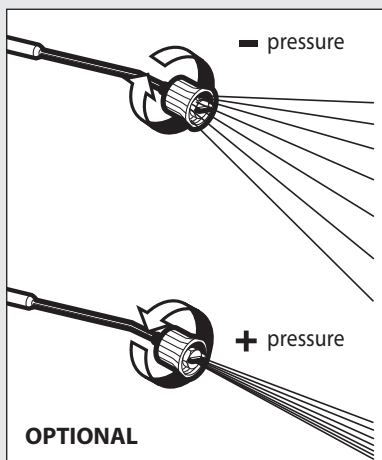

fig. E Optional

IT getto ventaglio EN spread pattern FR jet d'eau en eventail DE großen Wasserstrahl ES chorro grandes
 NL waaivormige straal PT jato grande EL πιδακας βεντάλια FI viuhkamainen suihku RU веерообразная струя SL pahljačasti curek vode HR mlaznica raspršivač
 BG Предпазител SV sluten NO samlet stråle CS široký paprsek

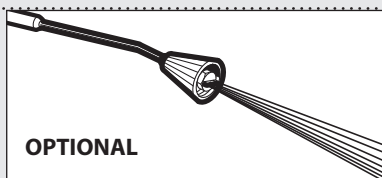
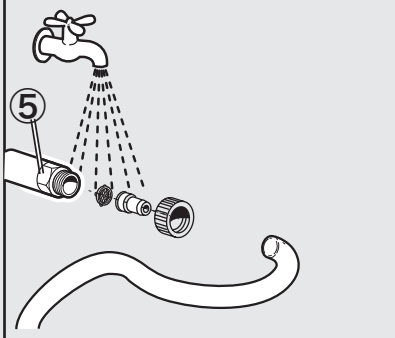
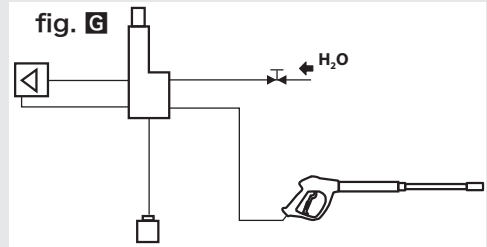

fig. F



- SCHEMA IDRICO
- WATER DIAGRAM
- SCHEMA HYDRAULIQUE
- WASSERUMLAUFSCHEMA
- ESQUEMA HÍDRICO
- WATERSHEMA
- ΣΧΕΔΙΟ ΥΔΡΕΥΣΗΣ
- ESQUEMA HIDRÁULICO
- VEDENKYTKENTÄKAAVIO
- ГИДРАВЛИЧЕСКАЯ СХЕМА
- SHEMA VODENOG KRUGA
- VODOVODNA SHEMA
- ВОДНА ДИАГРАМА
- VATTENSHEMA
- VANNSKJEMA

CS HYDRAULICKÉ SCHEMA



- | | | | |
|---------------------|-----------------------|--------------------|-------------------------|
| • SCHEMA ELETTRICO | • ESQUEMA ELÉCTRICO | • SÄHKÖKAAVIO | • ЕЛЕКТРИЧЕСКА ДИАГРАМА |
| • ELECTRIC DIAGRAM | • ELEKTRICITEITSSHEMA | • ЭЛЕКТРОСХЕМА | • KOPPLINGSSHEMA |
| • SCHEMA ELECTRIQUE | • ΗΛΕΚΤΡΙΚΟ ΔΙΑΓΡΑΜΜΑ | • ELEKTRIČNA SHEMA | • ELEKTRISK SKJEMA |
| • ELEKTROSHEMA | • ESQUEMA ELÉCTRICO | • ELEKTRIČNA SHEMA | • ELEKTRICKÉ SCHEMA |

fig. H

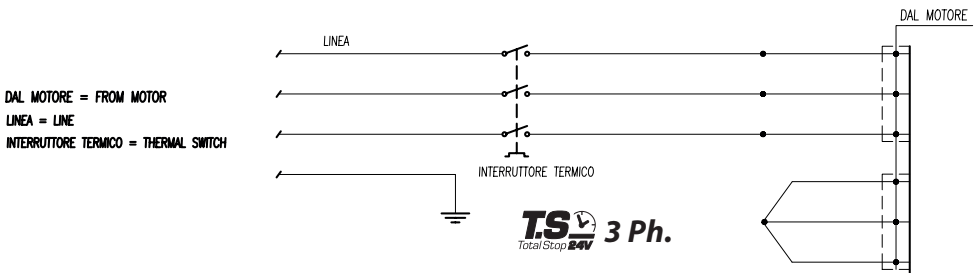
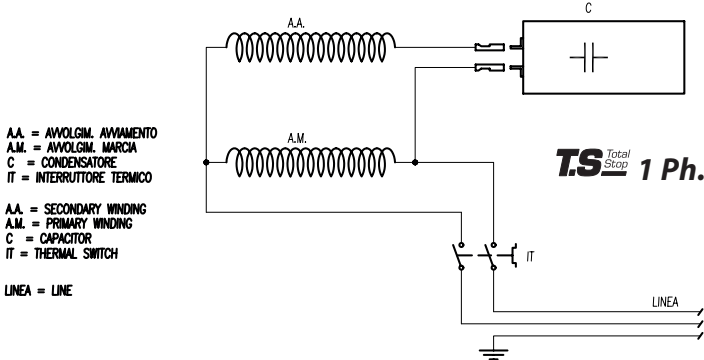

- A.A. – вторично ел.свързване
 A.M. – първично ел.свързване
 C - кондензатор
 IT – термичен ключ
 LINEA - линия
 DAL MOTORE – от мотора
 1 Ph - монофаза
 3 Ph - трифаза

INTRODUZIONE

> UTILIZZO PREVISTO

- Le prestazioni e la semplicità d'uso dell'apparecchio sono idonee ad un utilizzo **PROFESSIONALE**.
- L'apparecchio può essere usato per il lavaggio di superfici in ambienti esterni, ogni qualvolta si richieda l'uso di acqua in pressione per eliminare lo sporco.
- Con opportuni accessori opzionali si possono svolgere lavori di schiumatura, sabbiatura e lavaggi con spazzola rotativa da applicare alla pistola.

> DATI TECNICI

(vedi targhetta dati tecnici) pag. 63

> SIMBOLI



ATTENZIONE! Prestare attenzione per motivi di sicurezza.



IMPORTANTE



BLOCCATO



APERTO



SE PRESENTE



Doppio isolamento (SE PRESENTE): è una protezione supplementare dell'isolamento elettrico.

SICUREZZA

> AVVERTENZE GENERALI

- △**01 ATTENZIONE:** Apparecchio da utilizzarsi solo all'aperto.
- △**02 ATTENZIONE:** Alla fine di ogni lavoro, scollegare sempre il collegamento elettrico e idri-

co.

△**03 ATTENZIONE:** Non usare l'apparecchio se il cavo elettrico o parti importanti dell'apparecchio risultano danneggiate, es. dispositivi di sicurezza, tubo alta pressione pistola ecc.

△**04 ATTENZIONE:** Questo apparecchio è stato progettato per essere utilizzato con il detergente fornito o prescritto dal costruttore, tipo shampoo detergente neutro a base di tensioattivi biodegradabili anionici. L'impiego di altri detersivi o sostanze chimiche può compromettere la sicurezza dell'apparecchio.

△**05a ATTENZIONE:** Non utilizzare l'apparecchio in prossimità di persone, salvo il caso in cui queste indossino abiti protettivi.

05b - durante il lavoro non ammettete la presenza di persone o animali entro un raggio di 5 metri.

05c - operate sempre con abbigliamento adeguato per proteggersi contro l'eventuale rimbalzo di materiale asportato dal getto d'acqua ad alta pressione.

05d - non toccare la spina elettrica e l'apparecchio con le mani bagnate e a piedi nudi.

05e - indossate eventualmente occhiali di protezione e calzature con suola in gomma.

△**06 ATTENZIONE:** Il getto della lancia non deve essere indirizzato verso parti meccaniche contenenti grasso lubrificante: in caso contrario il grasso verrà disciolto e disperso sul terreno. I pneumatici e le valvole d'aria dei pneumatici devono essere lavati mantenendo una distanza minima di 30 cm; in caso contrario essi potrebbero essere danneggiati dal getto d'acqua alta pressione. Il primo segno di tale danneggiamento è dato dallo sbiadimento del pneumatico. Pneumatici e valvole d'aria dei pneumatici danneggiati sono pericolosi per la vita.



△**07 ATTENZIONE:** I getti ad alta pressione possono essere pericolosi se usati impropriamente. I getti non devono essere diretti verso le persone, gli animali, verso le apparecchiature elettriche vive oppure verso l'apparecchio stesso.

△**08 ATTENZIONE:** I tubi flessibili, gli accessori e i raccordi per l'alta pressione, sono importanti per la sicurezza dell'apparecchio. Utilizzare solamente tubi flessibili, accessori e raccordi prescritti dal costruttore (è estremamente importante preservare l'integrità di questi componenti evitando un uso improprio e prevenendoli da pieghe, urti, abrasioni).

△**09 ATTENZIONE:** Apparecchi non dotati di **T.S.** - Automatic Stop System: non devono rimanere

GENERAL INFORMATION

- This appliance's performance and userfriendliness make it suitable for **PROFESSIONAL** use.
- The appliance can be used for washing surfaces outdoors, whenever pressurised water is required to remove dirt.
- With special optional accessories, it can be used for foaming and sandingblasting, and for washing with a rotary brush for application to the gun.

> **THECNICAL DATA**

(see thecnical data plate) pag. 63

SYMBOLS



WARNING: It is important to be careful of the following items.



IMPORTANT



LOCKED



OPEN



IF PRESENT



Double insulated (IF PRESENT): supplementary insulation is applied to the basic insulation to protect against electric shock in the event of failure of the basic insulation.

SAFETY PRECAUTIONS

> **WARNINGS**

- ⚠ **01WARNING:** This appliance is for outdoor use only.
- ⚠ **02WARNING:** Always disconnect the electricity and water supplies on completion of every job.
- ⚠ **03WARNING:** Do not use the machine if a supply cord or important parts of the machine are damaged, e.g. safety devices,

high pressure hoses, trigger gun.

- ⚠ **04WARNING:** This appliance has been designed for use with the detergent provided or the detergent specified by the manufacturer, such as a neutral shampoo based on biodegradable anionic surface active detergents. The use of other detergents or chemicals may put the appliance's safety at risk.

- ⚠ **05a WARNING:** Do not use the machine within range of persons unless they wear protective clothing.

05b - Do not allow other people or animals within a range of 5m when operating the machine.

05c - Always wear suitable protective clothing in order to protect yourself against ricocheting parts.

05d - Do not touch the plug and the appliance with wet hands or when barefoot.

05e - Wear safety goggles and non-slip rubber footwear.

- ⚠ **06WARNING:** Do not direct the nozzle toward mechanical parts containing lubricant grease, as the grease will dissolve and spread over the surrounding ground. Vehicle tyres/tyre valves may only be cleaned from a minimum distance of 30 cm, otherwise the vehicle tyre/tyre valve could be damaged by the high-pressure jet. The first indication of this is a discoloration of the tyre. Damaged vehicle tyres/tyre valves can be deadly dangerous.

- ⚠  **07WARNING:** High pressure jets can be dangerous if subject to misuse. The jet must not be directed at persons, animal, live electrical equipment or the machine itself.

- ⚠ **08WARNING:** High pressure hoses, fittings and couplings are important for the safety of the machine. Use only hoses, fittings and couplings recommended by the manufacturer. (it is extremely important to protect these components against damage by avoiding their improper use and protecting them against bending, knocks and scratches).

- ⚠ **09WARNING:** Appliances not equipped with **T.S.** – Automatic Stop System: must not be left in operation for more than 2 minutes with the gun released. The recycled water heats up considerably, seriously damaging

the pump.

- ⚠ **10WARNING:** Appliances equipped with **T.S.** – Automatic Stop System: these appliances should not be left in standby for more than 5 minutes.
- ⚠ **11WARNING:** Switch the appliance off completely (master switch on (0)OFF) whenever it is left unattended.
- ⚠ **12WARNING:** Every machine is tested in its operating conditions, so it is normal for a few drops of water to be left inside it.
- ⚠ **13WARNING:** Take care not damage the electric cable. If the supply cord is damaged, it must be replaced by the manufacturer, its service agent or similarly qualified persons in order to avoid a hazard
- ⚠ **14WARNING:** Appliance with fluid under pressure. Keep a firm hold on the gun and be prepared to take the kickback pressure. Only use the high pressure nozzle provided with the appliance.
- ⚠ **16WARNING:** This appliance is not intended for use by persons (including children) with reduced physical, sensory or mental capabilities, or lack of experience and knowledge, unless they have been given supervision or instruction concerning use of the appliance by a person responsible for their safety.
- ⚠ **17WARNING:** Children should be supervised to ensure that they do not play with the appliance.
- ⚠ **18WARNING:** Never start the high-pressure cleaner without first completely unwinding the high-pressure hose.
- ⚠ **19WARNING:** When winding and unwinding the pipe take care not to cause the high-pressure cleaner to overturn.
- ⚠ **20WARNING:** Before unwinding or winding the hose, switch the machine off and release the pressure in the hose itself (switching off).
- ⚠ **21WARNING:** Risk of explosion — Do not spray flammable liquids.
- ⚠ **22WARNING:** To ensure machine safety, use only original spare parts from the manufacturer or approved by the manufacturer.
- ⚠ **23WARNING:** Do not direct the jet against yourself or others in order to clean clothes or foot-wear.
- ⚠ **24WARNING:** High pressure cleaners

shall not be used by children or untrained personnel.

- ⚠ **WARNING:** Water that has flown through backflow preventers is considered to be non-potable.
- ⚠ **XX WARNING:** the machine shall be disconnected from its power source, by removing the plug from the socket-outlet, during cleaning or maintenance and when replacing spare parts
- ⚠ **XJ WARNING:** If an extension cord is used, the plug and socket must be of watertight construction.
- ⚠ **XY WARNING:** Inadequate extension cords can be dangerous.
- ⚠ **WARNING:** It is absolutely forbidden to use the machine in potentially explosive environments or areas.
- ⚠ **WARNING:**
 - NEVER EVER TOUCH THE MACHINE WITH WET HANDS OR BARE FEET.
 - NEVER PULL THE POWER SUPPLY CABLE OR MACHINE IN ORDER TO DISCONNECT THE PLUG FROM THE SOCKET.
 - IF DURING FUNCTIONING THE POWER SUPPLY RUNS OUT, FOR SAFETY REASONS, TURN THE MACHINE OFF.

> **SAFETY DEVICE**

- ⚠ **WARNING:** the gun is fitted with a safety catch. Whenever use of the machine is interrupted it is important to operate the safety catch to prevent accidental activation of the jet.
 - Safety features: gun equipped with safety locking device, appliance equipped with (Class I) overload cutout, pump equipped with by-pass valve or shutdown device.
 - The safety button on the gun is not there to lock the lever during operation, but to prevent its accidental operation.
- ⚠ **WARNING:** The appliance is equipped with a motor protection device: in case of device intervention, wait some minutes or, in alternative, disconnect and re-connect the product to the electric system. In case this problem repeats again or if the product does not start again, take the product to the nearest After Sales Service Point

> **STABILITY**

- ⚠ **WARNING:** The machine must be always kept

on horizontal bases, in a safe and stable way.

> WATER SUPPLY

Water supply collection

Water supply from the water main

- Connect a supply hose (not included) to the water inlet of the unit and to the water supply.
- Open the water supply.



WARNING: (symbol) machine not suitable for connection to the potable water mains.

The cleaner can only be connected to the water mains if the water mains is separated by a backflow preventer. Make sure that the hose is at least \varnothing 13mm-1/2 inch and that it is reinforced.

⚠ WARNING: Water that has flown through backflow preventers is considered to be nonpotable.

🔧 IMPORTANT: Only clean or filtered water should be used for intake. The delivery of the water intake tap should be equal to the double of the maximum pump range.

- Minimum delivery rate: 30 l/ min.
- Maximum intake water temperature: 40°C
- Max inlet water pressure: 1Mpa

Place the cleaner as close to the water supply system as possible.

Water supply from an open container

- Unscrew the coupling part for the water inlet.
- Screw the suction hose with filter (not included) onto the water connection of the unit.
- Hang the filter in the container.
- Vent the unit before operation.
- Unscrew the high-pressure line at the high-pressure outlet of the unit.
- Switch on the unit and let it run until water free of bubbles emerges at the high-pressure outlet.
- Switch off the unit and screw on the high-pressure hose again.

Failure to comply with the above conditions causes serious mechanical damage to the pump and the loss of warranty cover.

> ELECTRICITY SUPPLY

- The appliance's electrical connection must comply with the IEC 60364-1 standard.

🔧 IMPORTANT: Before connecting the appliance, make sure that the nameplate data are the same as those of the electrical mains and that the socket is protected by a differential security breaker with tripping sensitivity below 0.03 A - 30 ms.

- If the appliance's plug is not compatible with the socket, have the socket replaced with another of suitable type by professionally qualified staff.
- Never use the appliance in ambient temperatures below 0° C if it is equipped with a PVC (H VV-F) cable.

⚠ XY WARNING: Inadequate extension cords can be dangerous.

⚠ XJ WARNING: If an extension cord is used, the plug and socket must be of watertight construction.

Information for supply may also be obtained from the plug manufacturer.

230-240V	400-415V
3G 2,5 mm ²	4G 2,5 mm ²
max 20 m	max 30 m

USAGE

> UNPACKING

(see fig. **B**)

Take out the upper and the lower hooks, which fix the cardboard box to the pallet, take the cardboard box off, put two wheels of the machine on ground and take the pallet off.

> DESCRIPTION OF THE MACHINE

(fig. **A**)

(if fitted)

T.S.^{Total Stop} (if fitted)

Machines equipped with delayed, low-voltage Total Stop:

When the machine is working, by releasing the gun lever, the motor stops automatically to prevent component wear during the pump by-pass phase (motor in stand-by).

By pressing the gun lever the motor starts automatically.

⚠ WARNING: do not leave the stand-by mode active for more than 5 minutes.

At the end of the operation, set the switch to "OFF".

T.S.^{Total Stop 24V} (if fitted)

Machines equipped with delayed, low-voltage Total Stop:

When the machine is working, by releasing the gun lever, after approximately 15 seconds the motor stops automatically to prevent component wear during the pump by-pass phase (motor in stand-by). By pressing the gun lever the motor starts automatically.

⚠ WARNING: do not leave the stand-by mode active for more than 5 minutes.

At the end of the operation, set the switch to "OFF".

Activate hand spray gun until device is pressure less.

If the appliance is equipped with a **pressure regulator**:

- when the pressure is set to minimum the **T.S.** may not trigger. Therefore, do not allow the appliance to function in by-pass for more than 1 minute.
- do not act on the gun lever too frequently (this may cause a malfunction).

> **APPLIANCES PROVIDED WITH THERMAL VALVE (OPTIONAL)**

This device enables the machine's by-pass operation through automatic water discharge whenever it reaches a temperature of nearly 60°C and cooling working components.

⚠ CAUTION: appliances that are not provided

with this disposal must not operate for more than 2 minutes with released gun. Recycled water raises its temperature remarkably causing great damages to the pump.

> **INSTALLATION AND START-UP**

> **INSTALLATION**

- Check that the master switch is turned to "OFF" and that the water filter is fitted into the pump's inlet pipe.
- Screw the snap connection into place by hand, without the aid of tools.
- Connect the water supply hose to the snap connection. The hose must have an inside diameter of at least 13 mm (1/2").
- Connect the high pressure hose to the pump's outlet pipe. Press the high pressure hose coupling fully down and then screw into place by hand without the aid of tools.
- Connect the high pressure hose to the gun. (fig. **B**)
- Turn the water tap fully on. The water temperature absolutely must be below 40°C.

⚠ IMPORTANT: The washer machine has to operate with clean water in order to avoid any damages to the washer machine itself.

- Release the gun safety catch and keep the trigger pressed, allowing the water to flow until all the air has been expelled.
- Fit the lance into the gun.
- Fit the nozzle into the lance.
- Connect the plug to the power socket.

> **1ST START-UP**

When starting up for the first time or after a long period out of use, connect the intake line only for a few minutes so that any dirt is vented from the delivery outlet

> **START-UP**

(fig. **C**)

- Whenever using the high-pressure cleaner, users are urged to hold the gun in the correct position, with one hand on the grip and the other on the spray rod.
- To start the machine, press the gun trigger and at the same time turn the master switch to "ON"

CARE AND MAINTENANCE

 **IMPORTANT:** Before doing any work on the cleaner, discharge the pressure and disconnect the electricity and water supplies.

CHECKING THE PUMP OIL LEVEL

Check the oil level periodically. The oil must be changed for the first time after 50 working hours, with subsequent changes every 500 hours. SAE 20/30 (750 gr) oil is recommended.

CHECKING THE WATER INTAKE FILTER

(see fig. )

Inspect and clean the water intake filter on the intake union periodically. This is important to prevent fouling which may impair operation of the pump.

CHECKING THE SPRAY ROD NOZZLE

Replace the nozzle when the pressure drops below the normal values.

DESCALING

The descaling procedure must be carried out periodically with specific products. The interval depends on the hardness of the water. Pour one litre of product for every 15 litres of water into a drum containing at least 30 litres of water. Disconnect the gun from the high pressure line and place its free end in the drum, in order to form a closed circuit, and draw the solution into the machine for at least 10 minutes. The delivery end of the line should discharge into a canvas or mesh bag so that the scale removed is not returned to the circuit. Then restore the normal connection and rinse with plenty of cold water. This operation should be carried out by our after-sales service, since the descaling product may cause wear of components. Comply with the regulations in force when disposing of the descaling agent.

ELECTRIC DIAGRAM

See illustrations, .

WATER DIAGRAM

See illustrations, .

TROUBLESHOOTING

Before doing any work on the machine, disconnect the electricity and water supplies and discharge the pressure. Proceed systematically to identify Faults following

the chart below; if you are still unable to eliminate the problem, call in the **Authorized After-Sales Service**.

Fault	When switch "ON" the machine will not start working
Cause	<ul style="list-style-type: none"> • Plug not properly inserted in socket. • Electric socket is faulty. • The main voltage is insufficient. • The pump is stuck. • Gauge of extension lead not sufficient.
Repair	<ul style="list-style-type: none"> • Fit plug in power socket correctly. • Have electrical socket checked. • Have a check made on the suitability of the mains system. • Turn switch to ON while keeping nozzle trigger pressed; if problem persists, contact an authorised service centre.

Fault	The motor stops suddenly
Cause	<ul style="list-style-type: none"> • Thermic safety switch has tripped due to the overheating. • Cable extension seems to be inadequate.
Repair	<ul style="list-style-type: none"> • Leave motor to cool for a few minutes. If the problem persists, contact an authorised service centre..

Fault	The pump doesn't reach the necessary pressure
Cause	<ul style="list-style-type: none"> • Insufficient flow. • Water inlet filter is clogged. • Suction/delivery valves are clogged or worn out. • Pressure regulator valve set on minimum. • The nozzle is worn out.

Repair	<ul style="list-style-type: none"> • Check that the delivery rate is 30% higher than the value stated on the appliance's technical data plate. • Remove and clean the filter. • Contact an authorised service centre. • Increase the pressure by screwing in the pressure regulator knob. • Replace the nozzle.
--------	--

Fault	Fluctuating pressure
Cause	<ul style="list-style-type: none"> • The nozzle is either clogged or deformed. • Suction/delivery valves are clogged or worn out. • Worn gaskets. • Pressure regulator valve gaskets worn. • The filter is dirty.
Repair	<ul style="list-style-type: none"> • Dismantle the lance and clean the nozzle with the pin provided. • Contact an authorised service centre. • Contact an authorised service centre. • Contact an authorised service centre. • Remove and clean the filter.

Fault	Water leak from appliance
Cause	<ul style="list-style-type: none"> • Water leaking from the pump. • Leaks from hose reel (if present). • Leaks from pressure regulator valve. • Leaks from water unions.
Repair	<ul style="list-style-type: none"> • Contact an authorised service centre. • Tighten the unions; if the problem persists, contact an authorised service centre. • Contact an authorised service centre. • Tighten the unions; if the problem persists, contact an authorised service centre.

Fault	Abnormal noise
Cause	<ul style="list-style-type: none"> • Suction/delivery valves are clogged or worn out. • Worn bearings. • The filter is dirty. • Extreme water temperature.
Repair	<ul style="list-style-type: none"> • Contact an authorised service centre. • Contact an authorised service centre. • Remove and clean the filter. • Bring the temperature under 50°.

Fault	Water is in the oil
Cause	<ul style="list-style-type: none"> • O-rings (water and oil) are worn out.
Repair	<ul style="list-style-type: none"> • Contact an authorised service centre.

> **REPAIRS - SPARE PARTS**

For any problems not mentioned in this manual, or if the machine breaks down, you are urged to contact an **Authorized After-Sales Service** for the relative repair or for any replacement of components with original spare parts. Use exclusively original replacement parts.

> **WARRANTY CONDITIONS**

All our machines are subjected to strict tests and are covered against manufacturing defects in accordance with applicable regulations. The warranty is effective from the date of purchase.

The following are not included in the warranty: - Parts subject to normal wear. - Rubber parts, charcoal, filters and the accessories and optional accessories. - Accidental damage, caused by transport, neglect or inadequate treatment, incorrect or improper use and installation failing - The warranty shall not cover any cleaning operations to which the operative components may be subjected, such as clogged nozzles and filter blocked due to limestones.

> DISPOSAL

As the owner of electrical or electronic equipment, the law (in accordance with the EU Directive 2012/19/EC on waste from electrical and electronic equipment and the national laws of the EU Member States that have implemented this Directive) prohibits you from disposing of this product or its electrical / electronic accessories as municipal solid waste and obliges you to make use of the appropriate waste collection facilities.

The product can be disposed of by returning it to the distributor when a new product is purchased. The new product must be equivalent to that being disposed of.

Disposing of the product in the environment can cause great harm to the environment itself and human health.

The symbol in the figure indicates the urban waste containers and it is strictly prohibited to dispose of the equipment in these containers. Non-compliance with the regulations stipulated in the Directive 2012/19/EC and the decrees implemented in the various EU Member States is administratively punishable.

MODELLO • MODEL • MODELE • MODELL • MODELO • MODEL МОНТЕЛО • MALLI • МОДЕЛЬ • MODELO • MODEL • MODEL • MODEL		1211 LP TS	1515 LP TS	2015 LP TS	2021 LP TS	2515 LP TS
Potenza ass. W • Power consump. W • Puissance W • Motor W • Potencia abs. en W • Aansluitvermogen W • Απ. ισχύς • Virrankulutus W • Потребл. мощность Вт • Potência abs. en W • Apsorbirana snaga. W • Porabljena moč W • Förbrukad effekt W • Adsorbent effekt W • Příklad W	230/240V Ph. 1~50Hz 400/415V Ph. 3~50Hz	3000	5000	7000	9400	8500
Motore • Motor • Moteur • Motor • Motor • Motor • Κινητήρας • Moottori • Двигатель • Motor • Motor • Motor • Motor	HP	3,5	5,5	7,5	10	9
Temp. di alimentazione (max.) • Supply temp. (max.) • Temp. maxi. d'arrivée d'eau • Zulauftemp.(max.) • Temp. del agua de entrada (máx.) • Aanvoertemperatuur (max.) • Θερμ. τροφοδότησης (μέγιστη) • Syöttölämpötila max. • Время подачи (макс.) • Temp. de admissão (máx.) • Vrijeme napajanja (maks.) • Temperatura napajanja (največ) • Matningstemperatur (max) • Forsyningstemperatur (maksimal) • Vstupní teplota vody (max.)	°C	40				
Portata di alimentazione (min.) • Supply rate (min.) • Débit mini. d'arrivée d'eau • Zulaufmenge (min.) • Caudal de alimentación (min.) • Min. ingaande water debiet • Παροχή τροφοδότησης (ελάχιστη) • Syöttövirtaama (min) • Пропускная способность подачи (мин.) • Quantidade de admissão (min.) • Nosivost napajanja (min.) • Zmogljivost napajanja (min) • Matningseffekt (min.) • Forsyningsskapasitet (minimal) • Vstupní průtok (min.)	l/min л/мин	30				
Pressione entrata max. • Pressure inlet max. • Pression entrée max. • Druck Einlauf max. • Presión entrada máx. • Max. Toevoedruk • Μέγιστη πίεση εισόδου • Syöttöpaine max. • Макс. входное давление • Pressão entrada máx. • Maksimalni ulazni pritisak • Maksimalni tlak na vstopu • SV Maximalt inmatningstryck • No Maksimalt trykk i inngang • Max. vstupní tlak	MPa	1				
Prevalenza per alimentaz. da serbatoio • Suction height from a tank • Hauteur d'aspiration dans un réservoir • Saughöhe aus offenem Behälter • Altura de aspiración desde un recipiente • Aanzuighoogte van een tank • Υπεροχή για τροφοδότηση από δεξαμενή • Pääasiallisesti säiliösyöttöinen • Высота напора из-за подачи от бака • Altura para alimentação desde reservatório • Prevaga za napajanje iz spremnika • Sesalna višina za napajanje posode • SV Uppsugningens höjd från tanken (optimalt) • NO Oppsugingshøyde fra beholderen (foretrukken) • Výška pro nasávání z otevřené nádrže	m	1,5				
Pressione max. • Pressure max. • Pression max. • Druck max. • Presión máx. • Max. druk • Μέγιστη πίεση • Paine max. • Макс. давление • Pressão máx. • Maks.pritisak. • Najvišji tlak • Maximalt tryck • Maksimal trykk • Max. tlak	MPa	12	15	20	20	25
Portata Max. • Volume Max. • Débit Max. • Leistung Max. • Caudal Max. • Max. Debit • Μέγιστη παροχή • Syöttövirtaama (max) • Макс. Пропускная способность • Capacidade máx. • Maks.nosivost. • Največja zmogljivost • Maximal effekt • Maksimal kapasitet • Max. průtok	l/min л/мин	11	15	15	21	15

MODELLO • MODEL • MODELE • MODELL • MODELO • MODEL MONTELO • MALLI • МОДЕЛЬ • MODELO • MODEL • MODEL • MODEL		1211 LP	1515 LP	2015 LP	2021 LP	2515 LP
Vibrazioni trasmesse all'utente • Arm vibrations • Vibrations transmises à l'utilisateur • Effektivbeschleunigung Hand-Arm Vibrationswert • Vibraciones transmitidas al usuario • Op de gebruiker overgebrachte trillingen • Ταλαντώσεις μεταδομένες στον χρήστη • Efektiivinen kiihtyvyyks käden-käsivarren tärinäärvo • Эффективное ускорение вибрации кисть/рука • Aceleração efectiva, valor relativo à vibração mão-braço • Vibracije koje se prenose na korisnika • prenos vibracij na uporabnika • Vibrationer som överförs till användaren • Vibrasjoner overført til brukeren • Vibrace přenášené na uživatele	m/s² m/c²	2	2,2	2,2	2,3	2,3
Forza di reazione sulla pistola alla pressione di lavoro (max) • Recoil force of gun at operating pressure (max) • Force de recul au niveau de la pistolet à la pression de service maxi • Rückstoßkraft an der Handspritzpistole • Fuerza de retroceso en la pistola a máx. presión de trabajo • Terugstotende kracht op het spuitpistool bij werkdruk (max) • Δύναμη αντίδρασης του πιστολιού ψεκασμού • Pistoolin takaiskukyky työraiveeseen nähden • Реакционная сила пистолета при рабочем давлении • Força de repulsão na pistola com uma pressão de regime (máx.) • Jačina reakcije pištolja u odnosu na radni pritisak (maks.) • Reakcijska sila na brizgalki z delovnim tlakom (največ) • Reaktionskraft på pistolen vid (maximalt) driftstryck Mått • Reaksjonskraft for pistolen ved arbeidstrykk (maksimalt) • Reakční síla na pistolí při (max.) prac. tlaku	N	28	43	50	70	70
Dimensioni • Dimensions • Dimensions • Abmessungen • Dimensiones • Maten • Διαστάσεις • Koko • Габаритные размеры • Dimensões • Dimenzije • Mere-Mål • Mål • Rozměry	mm mm	500 x 900 x 830				
Peso • Weight • Poids • Gewicht • Peso • Gewicht • Βάρος • Paino • Бес • Peso • Težina • Teža • Vikt • Vekt • Hmotnost	Kg kg	50	53	56	61	53

La ditta costruttrice si riserva il diritto di modificare senza preavviso i dati indicati • The manufacturer reserves the right to modify the declared data without advance notification • La maison se réserve le droit de modifier sans préavis les données déclarées • Das Haus behält sich das Recht vor, die genannten Angaben ohne Vorankündigung zu ändern • La empresa se reserva el derecho de modificar sin preaviso los datos declarados • De fabrikant behoudt zich het recht voor om de verklaarde gegevens zonder voorafgaand bericht te wijzigen • Η κατασκευαστική εταιρεία επιφυλάσσει το δικαίωμα να τροποποιήσει χωρίς προειδοποίηση τα υποδεικνυόμενα δεδομένα • Valmistaja pidättää oikeuden muuttaa tietoja ilman erillistä ilmoitusta • Изготовитель имеет право вносить изменения в указанные данные без предупреждения. • A empresa fabricante reserva-se o direito de modificar os dados indicados sem aviso prévio. • Poduzeće proizvođač ostavlja sebi na pravo da unese izmjene navedenih podataka bez da prethodno obavijesti o tome • Podjetje proizvajalca si pridržuje pravico do spremembe navedenih podatkov brez vnaprejšnjega obvestila • SV - Tillverkaren förbehåller sig rätten att utan föregående meddelande ändra de angivna uppgifterna • NO - Produsenten forbeholder seg retten til å endre de angitte dataene uten forhåndsvarsel • Výrobce si vyhrazuje právo zmenit uvedené údaje bez predchozho upozornění.



EL ΔΗΛΩΣΗ ΠΙΣΤΟΤΗΤΑΣ ΕΚ/ΕΕ σύμφωνα με τις Οδηγίες της (και των ακόλουθων τροποποιήσεων): **FI EY/ EU-VAATIMUSTENMUKAISUUSVAKUUTUS** direktiivien (ja niiden muutosten) mukaan: **RU ДЕКЛАРАЦИЯ СООТВЕТСТВИЯ ЕС/ЕВ** в соответствии с Директивой (и последующими изменениями): **SL IZJAVA ES/ EU O SKLADNOSTI** v skladu z direktivami (in sledecimi spremembami): **HR CE/EU-IZJAVA O SKLADNOSTI** : je u skladu sa direktivama, te njihovim naknadnim modifikacijama **BG ДЕКЛАРАЦИЯ ЗА СЪОТВЕТСТВИЕ**: Отговаря на директиви CE и последващи модификации **NO EF/EU-SAMSVARSEKTLÆRING** i samsvar med direktivene (og senere endringer): **SV EG/EU-FÖRSÄKRAN OM ÖVERENSSTÄMMELSE** i enlighet med direktiven (och efterföljande ändringar):

2006/42/EC
2014/30/EU
2000/14/EC
2005/88/EC
2011/65/EU

EL Δηλώνει υπεύθυνα ότι η μηχανή: **FI** Vakuuttaa omalla vastuullaan että kone: **RU** Объявляет под свою ответственность, что машина: **SL** Izjavlja pod lastno odgovornostjo, da je naprava **HR** Izjavljuje pod vlastitom odgovornošću da stroj: **BG** Декларираме на собствена отговорност че машина: **NO** forsikrer under eget ansvar at maskinen: **SV** Förklarar nedan sitt ansvar för att maskinen:

Lavorwash S.p.A
via J.F.Kennedy, 12 – 46020 Pegognaga (MN) – Italy

EL ΠΡΟΪΟΝ:	ΜΗΧΑΝΗΜΑ ΚΑΘΑΡΙΣΜΟΥ ΜΕ ΥΨΗΛΗ ΠΙΕΣΗ	MONTELOU-ΤΥΠΟΣ:	COLUMBIA LP	- P86.0354
FI TUOTE:	KORKEAPAINEPESURI	MALLI -ΤΥΠΡΡΙ:	COLUMBIA-R LP	
RU АППАРАТ:	ГИДРООЧИСТИТЕЛЬ ВЫСОКОГО ДАВЛЕНИЯ	МОДЕЛЬ-ТИП:	EXPLORER LP	
SL PROIZVOD:	VISOKOTLAČNI VODNI ČISTILNI APARAT	MODEL-VRSTE:	EXPLORER-R LP	
HR PROIZVOD:	VISOKOTLAČNI VODENI ČISTAČ	MODEL-TIP:		
BG ПРОДУКТ:	Водоструйка за измиване под налягане	Модел-Тип:	HYPER C LP	
NO PRODUKT:	HØYTTRYKKSVA SKER	MODELL TYPE:	HYPER-R CR LP	
SV PRODUKT:	HÖGTRYCKSTVÄTT	MODELL-TYP:		

EL είναι σύμφωνα με τις οδηγίες **EK/EE** και τις μεταγενέστερες τροποποιήσεις τους καθώς και με τους κανονισμούς EN και τις μεταγενέστερες τροποποιήσεις τους. **FI** On yhdenmukainen **EY/ EU** direktiivien ja niitä seuraavien standardimuutosten, ja niitä seuraavien standardimuutosten kanssa. **RU** соответствует требованиям директив **EC/EU** и последующих модификаций, EN и стандартам, и последующих модификаций. **SL** V skladu z direktivami in njunimi kasnejšimi spremembami ter s standardi **ES/EU**, in z njihovimi kasnejšimi spremembami. **HR** je u skladu sa direktivama **CE/EU**, te njihovim naknadnim modifikacijama te standardima EN, njihovim naknadnim modifikacijama. **BG** Отговаря на директиви **EC/EU** и последващи модификации и норми EN. **NO** er i overensstemmelse med **EF/EU** direktivene, og senere endringer, samt med standarderne og senere endringer : **SV** Överensstämmer med **EG/EU** direktiven och dess följande modifieringar och standarderna och dess följande modifieringar.

EN 60335-1
EN 60335-2-79
EN 62233:2008
EN 50581

EN 55014-1:2006+A1:2009+A2:2011
EN 55014-2:2015
EN 61000-3-2:2014.
EN 61000-3-3:2013.

EL Η συσκευή προσδιορίζεται στον αριθ.27 του συνημμένου Ι. Διαδικασία αξιολόγησης της πιστότητας σύμφωνα με το συνημμένο V. **FI** Laite on määritetty liitteen I kohdassa n°27. Vaatimustenmukaisuuden arviointimenettely liitteen V mukaan I. **RU** устройство не определено.27 корпуса I. Процедура оценки соответствия в соответствии с приложением V. **SL** aparat je določen v št. 27 priloge I. Izjava o skladnosti je v skladu s prilogo V. **HR** aparat je određen u br. 27 priloga I. Izjava o skladnosti u skladu je s prilogom V. **BG** приспособление в съответствие с №27 от приложението. I. Съответствие с процедури съгласно приложение V. **NO** (støytutslipp i miljøet fra utstyr til utendørs bruk): Utstyret er definert i nummer 27 i tillegg I. Anvendt metode for samsvarsvurdering i henhold til tillegg V. **SV** Apparaten beskrivs ingående i bilaga I, paragraf n. 27. Procedur för utvärdering av överensstämmelse enligt bilaga V.

LpA 78dB(A)	LwA 87dB(A) K (uncertainty) 2dB (A)	LwA 89dB(A)
EL Στάθμη ηχητικής πίεσης	Μετρημένη στάθμη ηχητικής ισχύος	Εγγυημένη στάθμη ηχητικής ισχύος
FI Äänen painetaso	Mitattu äänitehotaso	Taattu äänitehotaso
RU Уровень звукового давления	Акустическая измеренная мощность	Акустическая мощность предоставлено
SL Stopnja zvočnega hrupa	Izmerjen nivo zvočne moči	Zagotovljen nivo zvočne moči
HR Razina akustičnog pritiska	Izmjerena razina zvučne snage	Zajamčena razina zvučne snage
BG Акустично налягане	Измерено ниво на мощността на звука	Гарантирано ниво на мощността на звука
NO Akustisk trykknivå	Lydeffekt, målt	Lydeffekt, garantert
SV Akustisk trycknivå	Uppmätt ljudeffektnivå	Garanterad ljudeffektnivå

EL Ο τεχνικός φάκελος βρίσκεται στη στήνη 00

FI Tiedoston thecnique alkaen:

RU Технические брошюры на

SL Tehnični akti so pri podjetju

HR Tehnički akti nalaze se pri proizduceću

BG Технически файл при:

NO File thecnique fra:

SV Technisch dossier bij:

Lavorwash S.p.A
via J.F.Kennedy, 12
46020 Pegognaga
(MN) – Italy

Pegognaga 2018/05/05

dan
Giancarlo Lanfredi
(Legal Representative
Lavorwash S.p.A.)

IT DICHIARAZIONE CE/UE DI CONFORMITÀ ai sensi delle Direttive (e successive modificazioni): **EN EC/UE DECLARATION OF CONFORMITY** according to Directive (and following amendments): **FR DÉCLARATION CE/UE DE CONFORMITÉ** aux termes des directives européennes (et leurs modifications successives): **DE EG/EU-KONFORMITÄTSERKLÄRUNG** gemäß Richtlinien (und späteren Änderungen): **ES DECLARACIÓN CE/UE DE CONFORMIDAD** en virtud de las Directivas (y sus sucesivas modificaciones): **NL EG/EU-KONFORMITEITSVERKLARING** volgens de Richtlijnen (en latere wijzigingen): **PT DECLARAÇÃO CE/UE DE CONFORMIDADE** nos termos das Directivas (e modificações posteriores): **CS ES/UE Prohlášení o shodě** podle Směrnice (a jejich následných variant):



2006/42/EC
2014/30/EU
2000/14/EC -
2005/88/EC
2011/65/EU

Lavorwash S.p.A
via J.F.Kennedy, 12 – 46020 Pegognaga (MN) – Italy

IT Dichiara sotto la propria responsabilità che la macchina: **EN** Declares under its responsibility that the machine: **FR** Atteste sous sa responsabilité que la machine: **DE** Erklärt unter der eigenen Verantwortung die Maschine: **ES** Declara bajo su propia responsabilidad que la máquina **NL** Verklaart geheel onder eigen verantwoordelijkheid dat de machine: **PT** Declara sob própria responsabilidade que a máquina: **CS** Na vlastní zodpovědnost prohlašuje, že přístroj:

IT **PRODOTTO:** IDROPULITRICE AD ALTA PRESSIONE
EN **PRODUCT:** HIGH PRESSURE CLEANER
FR **PRODUIT:** NETTOYEUR HAUTE PRESSION
DE **PRODUKT:** HOCHDRUCKREINIGER
ES **PRODUCTO:** (HIDRO)LIPIADORA DE ALTA PRESIÓN
NL **PRODUCT:** HOGEDRUKREINIGER
PT **PRODUTO:** LAVADORA DE ALTA PRESSÃO
CS **PRODUKT:** VYSOKOTLAKY ČISTIČ

MODELLO-TIPO: COLUMBIA LP - P86.0354
MODEL - TYPE: COLUMBIA-R LP
MODELE-TYPE: EXPLORER LP
MODELL-TYP: EXPLORER-R LP
MODELO - TIPO: EXPLORER-R LP
MODEL - TYPE: HYPER C LP
MODELO - TIPO: HYPER-R CR LP
MODEL-TYP: HYPER-R CR LP

IT è conforme alle direttive **CE/UE** e loro successive modificazioni, ed alle norme **EN:** **EN** complies with directives **EC/EU** and subsequent modifications, and the standards **EN:** **FR** est conforme aux directives **CE/UE** et aux modifications successives ainsi qu'aux normes **EN:** **DE** entspricht folgenden **EG/EU**-Richtlinien einschließlich späteren Änderungen und EN-Normen: **ES** está en conformidad con las directivas **CE/UE** y sus sucesivas modificaciones y también con la norma **EN:** **NL** in overeenstemming is met de Richtlijnen **EG/EU** en latere wijzigingen daarop en de normen **EN:** **PT** está em conformidade com as directrizes **CE/UE** e as suas sucessivas modificações bem como com as normas **EN** e as suas sucessivas modificações. **CS** Je v souladu se směrnici **ES/UE** a jejich následnými změnami, a normami **EN:**

EN 60335-1
EN 60335-2-79
EN 62233:2008
EN 50581

EN 55014-1:2006+A1:2009+A2:2011
EN 55014-2:2015
EN 61000-3-2:2014.
EN 61000-3-3:2013.

2000/14/EC - 2005/88/EC **IT** 2000/14/EC: L'apparecchiatura è definita al n°27 dell'allegato I. Procedura di valutazione della conformità secondo l'allegato V. **EN** The appliance is defined by no. 27 of the enclosure I. Conformity evaluation procedure in accordance with enclosure V. **FR** L'outilage est défini par nr. 27 du annexe I. Procédure d'évaluation de la conformité conformément l'annexe V. **DE** Das Gerät ist am Nr. 27 der Anlage I bestimmt. Konformitätswertungsverfahren gemäß der Anlage V. **ES** El producto es definido en el n° 27 anexo I. Procedimiento de evaluación de la conformidad de acuerdo con el anexo V. **NL** De apparatuur wordt gedefinieerd van de n°27 volgens aanhangsel I. Wegingsmethode van de conformiteit volgens aanhangsel V. **PT** O produto é definido pelo n° 27 anexo I. Procedimento de avaliação da conformidade de acordo com anexo V. **CS** Zařízení je definováno pod č. 27 přílohy I. Postupy posuzování shody dle přílohy V.

LpA 78dB(A)

LwA 87dB(A) K (uncertainty) 2dB (A)

LwA 89dB(A)

- Livello pressione acustica
- Acoustic pressure
- Niveau de pression acoustique
- Schalldruckpegel
- Nivel de ruido
- Geluidsdrumniveau
- Nivel da pressão acústica
- Hladina akustického tlaku

- IT** Livello di potenza sonora misurato
- EN** Acoustic power measured
- FR** Niveau du puissance sonore mesuré
- DE** Abgemessenes Schalleistungsniveau
- ES** Nivel de potencia acústica mesurado
- NL** Geluidsdrumniveau LwA gemeten
- PT** Nivel de potencia acústica mensurada
- CS** Naměřená hladina akustického výkonu

- IT** Livello di potenza sonora garantito
- EN** Acoustic power granted
- FR** Niveau du puissance sonore garanti
- DE** Garantiertes Schalleistungsniveau
- ES** Nivel de potencia acústica garantido
- NL** Geluidsdrumniveau LwA gegarandeerd
- PT** Nivel de potencia acústica garantida
- CS** Garantovaná hladina akustického výkonu

- IT** Il fascicolo tecnico si trova presso
- EN** Technical booklet at
- FR** Dossier technique auprès de:
- DE** Das technische Aktenbündel befindet sich bei
- ES** El manual técnico se encuentra en:
- NL** Technisch dossier bij:
- PT** Processo técnico em:
- CS** Technická dokumentace se nachází v:

Lavorwash S.p.A
via J.F.Kennedy, 12
46020 Pegognaga
(MN) – Italy

Pegognaga 2018/05/05

Giancarlo Lanfredi
(Legal Representative
Lavorwash S.p.A.)